

Borough Council of
**King's Lynn &
West Norfolk**



Hackney Carriage And Private Hire Licensing Procedures & Conditions

Approved by Full Council: 30th January 2025

Table of Contents	Paragraph	Page
Table of Contents	-	1
Definitions	-	4
The Purpose of Licensing	-	5
Introduction	1.0	5
▪ The Borough Council's Role in Taxi Licensing	1.2	6
▪ Wheelchair Accessible Vehicles (WAV)	1.12	7
▪ Hackney Carriage / Private Hire Licences	1.14	7
▪ Referral to Panel of Licensing & Appeals Board	1.17	7
▪ The Licensing & Appeals Panel	1.19	7
▪ The Hearing	1.21	8
▪ The Decision	1.24	8
▪ Right of Appeal	1.27	8
▪ General Advice	1.28	9
▪ Serving of Notices	1.30	9
▪ Revocation of Licence	1.31	9
Application Process	2.0	10
▪ Driver Application	2.1	10
▪ Disclosure and Barring Service (DBS)	2.3	10
▪ Right to Work Checks	2.9	11
▪ Rehabilitation of Offenders Act 1988	2.10	11
▪ Driver's Medical – Group 2 DVLA Standard	2.11	11
▪ DVLA Driving Licence & Mandate	2.12	11
▪ Fees	2.13	12
▪ Knowledge Test	2.14	12
▪ NR3S Check	2.17	12
▪ Operators Application	2.18	12
▪ Vehicle Application	2.19	12
▪ Vehicle Licence Renewals	2.24	13
▪ Combined Driver Licence & Private Hire Operator Renewals	2.25	13
▪ Refund of Licence Fees	2.26	13
▪ Surrender of a Licence	2.28	14
▪ Death of a Licence Holder	2.29	14
All Vehicles	3.0	15
• Duration of Vehicle Licence	3.2	15
• Vehicle Replacement	3.3	15
• Insurance	3.6	15
• Excise Duty & Registration documents	3.9	16
• Age/Mileage Requirement	3.11	16
• Renewal of Vehicle Licences	3.12	16
• Exceptions to Age Requirement	3.14	16
• Vehicle Specifications	3.15	17
• Roof / Boot Racks & Bullbars	3.25	17
• Carriage of Portable Oxygen Tanks	3.26	17
• Vehicle Testing	3.27	18
• Altered Vehicles	3.33	19
• Vehicle Inspections	3.39	19
• Exterior Bodywork and Wheel Trims	3.40	19
• Accidents / Damage to Vehicle	3.41	20
• Fire Equipment and First Aid	3.43	20
• Change of Address	3.45	20
• Radio Devices	3.46	20
• CCTV Cameras	3.48	21
• Ventilation	3.50	21

Table of Contents	Paragraph	Page
<ul style="list-style-type: none"> • Interior • LPG Conversions (existing licensed vehicles) • LPG Conversions (new applications) • Tinted Windows • Unfit Vehicle Notices • Advertising • Licences and Plates • List of Drivers to be maintained • Trailers • Change of Use • Transfer of Vehicle • Alteration of Vehicle • Passengers 	<p>3.51 3.54 3.55 3.58 3.59 3.63 3.65 3.70 3.71 3.73 3.74 3.75 3.76</p>	<p>21 21 22 22 22 23 23 24 24 25 25 25 25</p>
<p>Hackney Carriage Vehicles</p> <ul style="list-style-type: none"> • Restriction on Numbers of Licensed Vehicles • Intended Use • Wheelchair Accessible Specifications • Wheelchair Occupant Space • Lifts / Ramps • Ramps • Lifts • Wheelchair Securing Mechanism Anchorage • Wheelchair Securing Mechanism • Taximeters • Inspection of Taxi Meter • Roof Signs • Unattended Taxis 	<p>4.0 4.2 4.3 4.4 4.7 4.8 4.9 4.10 4.11 4.12 4.13 4.21 4.24 4.29</p>	<p>26 26 26 27 27 27 27 27 28 28 29 29 29</p>
<p>Private Hire Vehicles</p> <ul style="list-style-type: none"> • Vehicle Signage • Roof Signs 	<p>5.0 5.1 5.5</p>	<p>30 30 31</p>
<p>Special Event Vehicles</p> <ul style="list-style-type: none"> • Application in Writing • Sale of Alcohol • Types of Vehicle • Age Requirements • Licence Plate • Communication Equipment • Dress Code • Minimum Booking Fee • Stretched Limousines • Replacement parts • Private Hire Operator – Additional Requirements 	<p>6.0 6.1 6.2 6.3 6.4 6.7 6.8 6.9 6.10 6.11 6.15 6.16</p>	<p>32 32 32 32 32 32 32 33 33 34 34</p>
<p>Combined Hackney Carriage & Private Hire Drivers</p> <ul style="list-style-type: none"> • General requirements • Conduct of Driver • Vehicle Checklist • Change of Address • Change of Operator • Convictions, Cautions, Driving Offences & Charges • Badges • DVLA Driving Licence 	<p>7.0 7.1 7.12 7.13 7.14 7.15 7.16 7.20 7.22</p>	<p>35 35 37 37 37 37 38 38 38</p>

Table of Contents	Paragraph	Page
<ul style="list-style-type: none"> • Prompt Attendance • Passengers • Lost Property / Misplaced Articles • Animals • Breakdowns • Fare to be demanded • Written Receipts • Passenger Transport Badge Holders • Smoking and Electronic Cigarettes • Failure to Provide Information • Equalities Act 2010 	<p>7.23 7.24 7.29 7.31 7.33 7.34 7.35 7.36 7.37 7.39 7.40</p>	<p>38 38 39 39 39 39 39 39 39 40 40</p>
Private Hire Operators	8.0	42
<ul style="list-style-type: none"> • General requirements • Complaints • Change of Address • Convictions, Cautions, Driving Offences & Charges etc • Use of Passenger Carrying Vehicles (PCV) • Public Liability Insurance 	<p>8.1 8.20 8.21 8.22 8.29 8.30</p>	<p>43 44 44 44 45 45</p>
Hackney Carriage Byelaws	9.0	46
Penalty Points Systems	10.0	51
Summary of Offences	11.0	54
Vehicle Accident Notification Form	Annex A	56
Guidelines relating to the relevance of convictions	Annex B	58
Immediate revocation of HC/PH Driver's Licence	Annex C	68
HC & PH Vehicle Compliance Testing Standards (Code of Practice)	Annex D	69
Vehicle Check sheet	Annex E	83

Definitions

- “**Borough Council**” means the Borough Council of King's Lynn & West Norfolk.
- “**Authorised officer**” means an officer of the Borough Council authorised in writing;
- “**Driver's licence**” means, in relation to the driver of a hackney carriage, a licence under section 46 of the Town Police Clauses Act 1847 and, in relation to the driver of a private hire vehicle, a licence under section 51 of Local Government (Miscellaneous Provisions) Act 1976;
- “**Hackney carriage**” or “**Taxi**” means a carriage exposed for hire to the public, whether standing in the public street or a private yard. The name is derived from an old French word denoting an ambling horse or mare: Oxford English Dictionary;
- “**Hackney carriage byelaws**” means the byelaws for the time being in force in the controlled district of the Borough Council relating to hackney carriages;
- “**Private Hire Vehicle**” is a motor vehicle constructed or adapted to seat fewer than nine passengers, other than a hackney carriage or public service vehicle which is provided for hire with the services of a driver for the purpose of carrying passengers. Private hire vehicles cannot ply for hire on a rank or be hailed in the street and must be pre-booked through a private hire operator licensed by the Borough Council.
- “**Operate**” means in the course of business to make provision for the invitation or acceptance of bookings for a private hire vehicle;
- “**Operator's licence**” means a licence issued by the Borough Council under section 55 of the Local Government (Miscellaneous Provisions) Act 1976;
- “**Taximeter**” means any device for calculating the fare to be charged in respect of any journey in a hackney carriage by reference to the distance travelled or time elapsed since the start of the journey, or a combination of both;
- “**Vehicle licence**” means in relation to a hackney carriage a licence under sections 37 to 45 of the Town Police Clauses Act 1847 and in relation to a private hire vehicle means a licence under section 48 of Local Government (Miscellaneous Provisions) Act 1976.
-
- “**Special Event Vehicle**” means a private hire vehicle exclusively used for special occasions. For further information see Section 6.
- “**Hackney Rank/Stand**” A designated place adopted by the Borough Council where hackney carriages can wait the arrival of a hirer.
- “**Notify the Borough Council**” means notify the Licensing Team at the Borough Council in writing.
- “**Home Address**” – is the address at which the licence holder/applicant lives, being their place of residence to which utility bills and their DVLA driving licence is registered to.

The Purpose of Licensing / Licensing Objectives

Drivers. The aim of the licensing regime is to ensure that, so far as possible, those licensed to drive either a Hackney Carriage or Private Hire vehicle are suitable persons to do so. Suitable means that they are safe drivers with good driving records and adequate experience, sober, mentally and physically fit. They also should be honest individuals who would not take advantage of their position to abuse, assault or defraud customers. The general term used in taxi licensing to describe this person is 'fit and proper'. The test when considering whether an applicant/licence holder is 'fit and proper' is to pose oneself the following question, 'Without any prejudice, and based on the information before you, would you allow a person for whom you care, regardless of their condition, to travel alone in a vehicle driven by this person at any time of the day or night?'

Vehicles. The Borough Council expects all licensed vehicles to be maintained to the highest standard at all times. The Borough Council also expects all licensed Hackney Carriages to work predominantly within the district of the Borough Council.

Operators. The Borough Council expects licensed operators to provide a first class customer service in order to promote a high standard to those who live in, work in, or visit the area.

1.0 Introduction

1.1 The Borough Council of King's Lynn & West Norfolk is situated in the County of Norfolk. The Council area has a population of 154,325 (Norfolk Insight 2021). In terms of area it is also the largest, covering 1428.76 square kilometres (551 square miles). The Borough area is mainly rural with urban areas of King's Lynn, Downham Market and Hunstanton. These areas are shown on the following map:

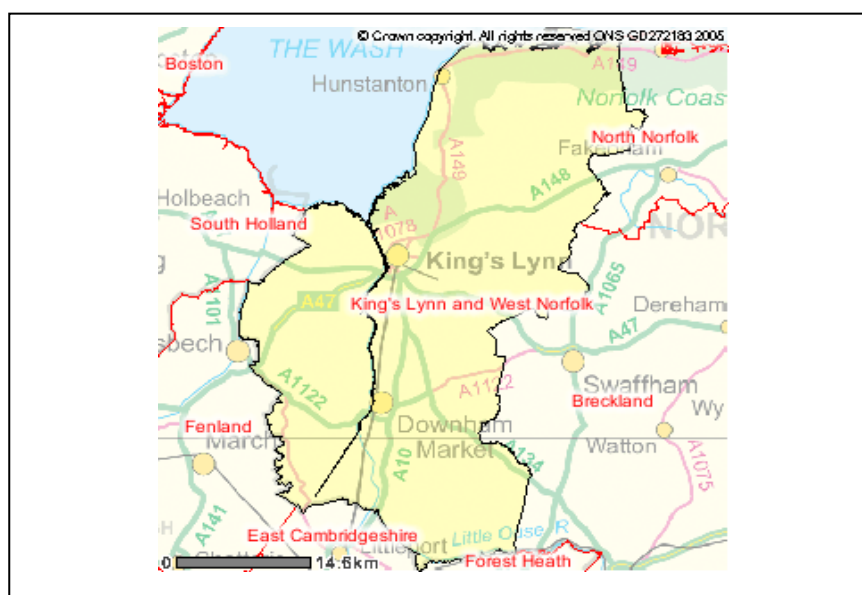

The Borough Council's Role in Taxi Licensing

- 1.2 The Borough Council is responsible for the licensing of all hire vehicles which operate within the district, which are provided with a driver and operated with less than nine passenger seats.
- 1.3 There are two types of vehicle: public hire vehicles (**Hackney Carriages**) and vehicles which are only available by prior booking arrangement (**Private Hire Vehicles**). Although the description 'taxi' should only be applied to a Hackney Carriage any hire vehicle is usually known as a 'taxi' by the public.
- 1.4 Before any vehicle is licensed it must be tested at one of the Borough Council's approved garages. The test covers the vehicle's mechanics and general appearance, which includes the comfort for passengers and the reliability of any meter fitted.
- 1.5 Private Hire vehicles may only undertake journeys in response to advance bookings. The Borough Council is also responsible for granting Private Hire Operators licences for the premises at which these bookings are made.
- 1.6 The Borough Council is responsible for the licensing of the drivers of both classes of vehicle. Within the scope of legislation the Borough Council ensures that all licence holders are 'fit and proper persons' to be licensed by carrying out checks on an applicant's background.
- 1.7 The Borough Council issue dual driver's licences to all successful applicants, which enables the holder to drive either a Hackney Carriage vehicle or a Private Hire vehicle provided that these vehicles are licensed by this authority.
- 1.8 As part of ensuring drivers are suitable for the role, the Borough Council carries out enhanced Disclosure and Barring Service checks. For more information, visit the Disclosure and Barring Service (DBS) website at www.gov.uk/government/.../disclosure-and-barring-service.
- 1.9 The Borough Council also has a responsibility as the 'Enforcement Agency' of the drivers, vehicles and operators it has licensed. Enforcement covers offences related to 'taxi' legislation, driver's behaviour, the condition of the vehicles and the investigation of complaints made against any licence holder.
- 1.10 As well as granting and issuing licences the Borough Council also has the power to suspend or revoke licences and take relevant enforcement action if necessary against any offending licence holder.
- 1.11 Licensing and enforcement is carried out by Borough Council of King's Lynn & West Norfolk's appointed 'Authorised Officers' for that purpose and they have been issued with written authority to do so as well as having a Borough Council identity badge.

Wheelchair Accessible Vehicles (WAV)

- 1.12 There are a number of wheelchair accessible vehicles available in West Norfolk which are licensed by the Borough Council. All new Hackney Carriage Vehicles (plates 53 onwards) registered with the Borough Council must be wheelchair accessible.
- 1.13 The Borough Council welcomes views and information from the public regarding their needs for wheelchair accessible vehicles, the availability of currently licensed vehicles or what would help to provide an efficient 'taxi' service for people with physical disabilities.

Hackney Carriage/Private Hire Licences

- 1.14 In considering applications for Hackney Carriage/Private Hire Licences and also any breaches during the currency of a licence, the Borough Council must be satisfied that drivers are fit and proper persons to hold a Licence. Any matter can be taken into consideration when determining 'fit and proper'.
- 1.15 The Borough Council will have regard to all convictions, police cautions, charges, driving convictions, complaints of unacceptable conduct or behaviour, breach of licence conditions and other convictions obtained, during the course of a Licence, in accordance with the convictions policy (see Annex B).
- 1.16 When such circumstances occur the application may be referred to a panel of the Licensing & Appeals Board for determination.

Referral to Panel of Licensing & Appeals Board

- 1.17 Where an applicant or a driver is referred to a panel for consideration, they will be notified in writing of the reason and the date, time and venue of the panel hearing.
- 1.18 They will be advised that they may bring a representative to the hearing. The representative may be a friend, legal representative or a representative from the trade whom they wish to assist them in addressing the panel in support of their application/disciplinary hearing. But please note that any consultation with a representative should take place in advance of the hearing date and not just prior to the meeting. This will ensure that their case is well prepared for panel consideration.

The Licensing & Appeals Panel

- 1.19 The panel will consist of three members made up of Borough Councillors who are members of the Licensing & Appeals Board. A Chairman is appointed to manage the hearing process. The Committee may be advised by a legal representative.
- 1.20 A number of Borough Council Officers may also attend the hearing, in an advisory capacity. However, they do not take part in the decision making process.

The Hearing

- 1.21** A number of applications and disciplinary matters could be considered on the day, including any historic matters. Each matter will be considered on its own merits and the public will be excluded to protect confidentiality where appropriate. In these circumstances the public will not have access to the meeting unless the applicant requests that they should.
- 1.22** When a person is called to appear before the panel they and their representative and any complainants will be guided to their seats. They will be asked if they have received a copy of the report regarding the circumstances surrounding their case. The panel will already have a copy of the report. Where the case arises from a complaint, the complainant, if present, will be asked to explain their complaint to the panel. There will be an opportunity to question the complainant.
- 1.23** The Licence Holder/New Applicant will be asked to describe the circumstances surrounding the convictions or incident concerned and asked to demonstrate to the panel why they think they are a fit and proper person to hold a Hackney Carriage/ Private Hire Drivers Licence or why they feel disciplinary action should not be taken.

The Decision

- 1.24** When considering convictions, the panel will have regard to the 'Guidance relating to the relevance of convictions and cautions' a copy of which is attached at Annex B.
- 1.25** After hearing the evidence and representations from all parties, the panel will retire to make their decision. Any person present not involved in the decision making process will be asked to leave the room.
- 1.26** As soon as the panel have come to a decision they will recall the persons who have left the room and read out their decision. The person will also be advised of the decision in writing together with their rights of appeal. The panel have a number of options which include the following:
- Grant or refuse application
 - Take no action
 - Issue a verbal warning
 - Suspend or revoke the licence
 - Apply conditions to the licence
 - Require driver to complete driving assessment and/or sit Borough Council's Knowledge Test, or any other action deemed appropriate.

Right of Appeal

- 1.27** If the Borough Council refuses the grant of a Vehicle, Operator or Drivers Licence, or in the case of a disciplinary hearing, decide to suspend or revoke a Drivers Licence or any other formal action, the person will have the right of appeal to a Magistrates' Court. In the case of refusal to grant a Hackney Carriage Proprietors Licence, appeal will be to the Crown Court.

General Advice

- 1.28** The Licensing & Appeals Panel is a formal meeting where members sit in a quasi-judicial manner. This means that the panel has to act in a similar fashion to a Court or Tribunal. It is therefore important that persons appearing before Committee should behave and dress in an appropriate manner and be present in good time before the hearing is due to commence.
- 1.29** If a person appears before the panel following a complaint about their conduct, they should not attempt to speak to the complainants / witnesses prior to the meeting as this could be deemed to be harassment.

Serving of Notices

- 1.30** Sub-sections (2) to (5) of S233 of the Local Government Act 1972 shall have effect and are incorporated in the conditions for vehicles, operators and drivers in relation to any notices required or authorised by the conditions to be given or served on the licensee by or on behalf of the Borough Council or any authorised officer.

Revocation of Licence

- 1.31** In the event of a Combined Driver's Licence or Private Hire Operator's Licence being revoked by the Borough Council the holder will be barred from re-applying for a period of 12 months from the date of the decision. Each case will be decided upon its individual merits.
- 1.32** In the event of a vehicle licence being revoked by the Borough Council, any further application to licence the vehicle will be treated as a new application.

2.0 Application Process

Driver Application

- 2.1** In addition to the application form, all applications for the grant of new driver licences must be accompanied by the following:
- 2.1.1 Disclosure and Barring Service (DBS) form;
 - 2.1.2 Medical Certificate;
 - 2.1.3 DVLA Driving Licence – (photocard or paper licence);
 - 2.1.4 DVLA check code;
 - 2.1.5 Fees;
 - 2.1.6 Passport Size Photograph certified as being a true likeness;
 - 2.1.7 Driver Assessment (to the former DSA standard) pass report;
 - 2.1.8 Additional documents may be required such as to ensure that the applicant has the right to work in the UK.
- 2.2** An application for a Combined Driver licence must be fully completed within a 6 month period otherwise the application will be rejected. In circumstances where documentation (such as DBS) is submitted before the application, the 6-month period will be calculated from the date the DBS (or other document) is received.

Disclosure and Barring Service form (DBS)

- 2.3** The application process requires the applicant to obtain a Disclosure and Barring Service (DBS) disclosure certificate to ‘enhanced’ standard. The certificate must be issued showing the occupation of “Other workforce Taxi/Private Hire Driver”, other occupations will not be accepted. The Borough Council is a ‘registered’ body with the DBS and as such, applications for disclosures must be made via this Authority on one of the pre-printed forms. Applicants that already have a disclosure showing the correct occupation and are signed up to the online update service, must provide their original disclosure certificate and any information required by the Borough Council to access their record online.
- 2.4** For applicants who have not signed up to the online update service the DBS Disclosure certificate must be dated within 6-months of the date a licence is issued and a new DBS application with sign up to the update service will be required before the licence will be issued.
- 2.5** Although the Borough Council submits the application form, the DBS Disclosure is sent directly to the applicant. The original disclosure document must therefore be produced to the Borough Council who will take a copy. Once the DBS certificate is received, the applicant must sign up to the DBS online update service within 28 days. A Disclosure that reveals conviction(s) may mean that an application will have to be considered by Members of the Licensing & Appeals Board.
- 2.6** If an applicant has been resident in any other Country than the UK over the age of 10 years old, preceding an application, a certificate of good conduct from an overseas embassy, or each overseas embassy where the applicant has lived, will be required in addition to the DBS Disclosure.
- 2.7** Usage. Information revealed on a DBS Disclosure will only be used for the

purpose of determining whether an applicant is 'fit & proper' or in the case of a review whether they continue to remain 'fit & proper' when assessing the continued suitability to hold a licence.

- 2.8** Retention. The Borough Council will retain a copy of the DBS Disclosure in accordance with the Council's retention policy.

Right to Work Check

- 2.9** The Borough Council will not issue a Hackney Carriage or Private Hire licence unless the individual has a right to work in the UK. All applicants must therefore provide documentation to prove that they have the right to work in the United Kingdom. The Borough Council will use a right to licence check sheet which is based upon the Home Office - A 'Right to work Checklist' providing a list of valid documentation. An application from a person who cannot provide the necessary documentation will be refused by officers under delegated authority.

Rehabilitation of Offenders Act 1974

- 2.10** Applicants for Hackney Carriage and Private Hire licensing are exempt from the Rehabilitation of Offenders Act 1974. Therefore all convictions, regardless of how long ago may be taken into consideration when determining applications. However, in determining the relevance of convictions the panel will take into account the type of offence, the age of the applicant at the time of the offence and the apparent seriousness of the offence, and in accordance with the conviction policy at Annex B.

Driver's Medical

- 2.11** A medical assessment report will be required upon initial application and must be carried out by a registered Medical Practitioner to group 2 DVLA standards using the Borough Council's approved form. Subsequent medicals will be required at age 45, then every five years after the age of 45 and then annually from the age of 65 years. A driver under the age of 65 with a controlled medical condition may also be required to undergo a full medical assessment annually. Medical forms produced with the initial application must be dated by the medical practitioner no longer than 6-months before the date a determination for a licence is made. It is important to ensure medical assessment reports are current and failure to produce a new report when requested may lead to the suspension of a combined licence. Where a doctor provides specific guidance this may be included as an additional condition on a licence.

DVLA Driving Licence & Check Code

- 2.12** All applicants must provide a current copy of their DVLA driving licence showing their current home address. There is also a requirement to provide a DVLA check code, which is valid for 21 days, allowing the Council to obtain the applicant's driving licence history from the DVLA. There is also a requirement to complete an Annual Update Check (DVLA and disclosure) throughout the licensed period.

Please note: If an applicant has 9 or more current penalty points and/or any previous convictions appear on their DVLA driving licence the application may be referred to a Panel of the Licensing & Appeals Board to ascertain whether they are a 'fit and proper' person to hold a licence.

Fees

- 2.13** Applications will not be accepted without the appropriate fee. It should be noted that the Borough Council only accepts payment made by either cheque or credit/debit card. Any licence in respect of which the licence fee has been paid by cheque shall not be effective until the cheque has been cleared.

Knowledge Test

- 2.14** The Borough Council's Knowledge Test contains multiple choice questions covering the following:

- Basic Maths and English (includes a listening test)
- The Highway Code
- Licensing Conditions and Legislation
- Places of Interest
- Safeguarding
- Disability Awareness

- 2.15** The test will be conducted in person and supervised by a member of staff from the Borough Council.

- 2.16** Applicants may attempt the knowledge test up to three times. After a third failed attempt the application will be rejected and the applicant will not be able to re-apply for six months from the date of the last failed attempt.

NR3S Check

- 2.17** The Borough Council has signed up to the National Register of Refusals and Revocations (NR3S register). This means that when an application for a taxi driver's licence is refused, or when an existing taxi driver's licence is revoked, that information will be placed on the register. The details of all new applicants will also be checked against the information held on the register.

Operators Application

- 2.18** Any person who receives bookings or has contracts for the hire and reward for a private hire vehicle is required to hold an Operator Licence. The application must be accompanied with a list of vehicles and drivers used by the operator. An operator must be a 'fit and proper person' and is therefore required to provide a basic DBS disclosure certificate upon initial application and annually thereafter. Note: This is not required where a driver's licence is already held and a current DBS has been provided to enhanced level.

Vehicle Application

- 2.19** A vehicle application can be processed within 3 days if all the relevant information has been supplied as below and the vehicle meets current conditions (i.e. age/mileage).

2.20 Registration Document or Bill of Sale. For initial applications only an original V5C (vehicle registration document) must be provided. A bill of sale for that vehicle may be produced if the V5C is not available but this must include the date of first registration and the original V5C document must be produced within a calendar month.

2.21 Insurance Certificate. A valid insurance policy and schedule or cover note covering the vehicle for Private Hire and/or Hackney Carriage work may be produced and the full insurance certificate provided within one calendar month thereafter. Emailed copies of insurance documents are acceptable provided that the insurance company's original email is forwarded to the licensing team (ehlicensing@west-norfolk.gov.uk).

Note: Any driver insured to drive a licensed vehicle must hold a Combined Drivers Licence.

2.22 Vehicle Inspection/MOT. All vehicles licensed by this Authority require inspection at an approved testing station (a list of approved garages can be found on the vehicle application form).

2.23 Disclosure & Barring Service (DBS). A vehicle licence applicant is required to provide a basic DBS disclosure certificate upon initial application and annually thereafter whilst a vehicle licence is held. Note: This is not required where a driver's licence is already held and a current DBS has been provided to enhanced level.

Vehicle Licence Renewals

2.24 Vehicle renewal applications will be accepted up to one calendar month before they are due to expire providing the MOT certificate/Compliance Test Certificate is no more than one calendar month older than the renewal date. Vehicle licences will not be granted an earlier renewal date than their current expiry date. Vehicle Registration documents (V5C) are not required to be produced upon renewal of a vehicle licence, providing there has been no material changes to that vehicle/document during the proceeding licence period. Once a licence has expired it cannot be renewed and any application received after the expiry date will be treated as a new application, unless there are exceptional circumstances.

Combined Driver Licence & Private Hire Operator Renewals

2.25 Combined Driver Licence and Private Hire Operator's Licence renewals will be accepted up to one calendar month before they are due to expire. Any application received after a licence has expired will be treated as a new application; unless there are exceptional circumstances.

Refund of Licence Fees – (not applicable to Insurance/lease vehicles)

2.26 In the event that a driver, vehicle or operator licence is not granted then the Borough Council will refund the licence application fee. This does not apply to the other fees e.g. knowledge test and DBS disclosure application.

- 2.27** Should a driver, vehicle or operator licence be surrendered during the life of the licence then a pro-rata refund (excluding original costs of processing the application minus an admin fee) will be given for the unexpired portion of the licence. The date will be calculated from the date the licence is returned to the Borough Council. Refunds will not be given for licences that are suspended or revoked.

Surrender of a Licence

- 2.28** Surrender of a Driver, Vehicle or Operator licence may be refused in the event of an ongoing investigation or pending disciplinary action against the licence holder.

Death of Licence Holder

- 2.29** A licence will immediately lapse in the event of death of the licence holder. In the case of a vehicle licence, a licence may be transferred using the normal procedure within 3 calendar months. A private hire operator's licence cannot be transferred into another person's name.

3.0 All Vehicles

- 3.1** The Borough Council will not grant or renew a vehicle licence unless they are satisfied that the vehicle to be licensed, is in a suitable mechanical condition, safe, clean and comfortable. Applications to renew licences will only be accepted up to the expiry date of the previous licence and any submissions received after that date will be treated as a new application.

Duration of Licence

- 3.2** A vehicle licence will be issued for a maximum period of one year, except in the case of a vehicle replacement; see Condition 3.4 (below).

Vehicle Replacement

- 3.3** Where a vehicle is off the road due to accident damage, the Borough Council may allow a replacement vehicle that meets the full criteria for the Hackney Carriage/ or Private Hire Vehicle being replaced. In the case of a Hackney Carriage replacement for plate number 53 onwards the replacement vehicle must be a wheelchair accessible vehicle (e.g. not a saloon car).
- 3.4** The vehicle will be licensed as a replacement for the accident damaged vehicle for a period not exceeding 3 months. A 50% reduction to the normal application fee and a full licence plate fee will be required.
- 3.5** Whilst being repaired, the vehicle licence number will be temporarily transferred to the lease vehicle (for Hackney) or suspended in which case the licence plate must be returned to the authority. Once repaired, a new vehicle inspection report may be required and the suspended licence may be re-instated. The licence holder may transfer the Fire Extinguisher and First Aid kit to the replacement vehicle whilst in use but must remember to transfer it back before the vehicle is returned.

Insurance

- 3.6** A vehicle must have a current certificate of insurance or cover note which clearly covers the use to which the vehicle is to be put.
- 3.7** It shall be the responsibility of the proprietor of a licensed vehicle to produce proof of continuous insurance cover. The insurance schedule must also be provided with the certificate. The insurance proof is to be received and reviewed by the licensing authority within seven days of the expiry of the preceding certificate or cover note.
- 3.8** If the proprietor fails to produce the required proof of insurance cover on request they must produce it forthwith or within seven clear days of the request to an authorised officer of the Borough Council. Failure to comply may result in the immediate suspension of the vehicle licence by authorised officers using delegated authority. The suspension will remain in place until a satisfactory certificate and schedule of insurance is produced.

Excise Duty (Road Tax) & Vehicle Registration Document (V5C)

- 3.9** There must be a valid excise duty for the vehicle at all times.
- 3.10** A full vehicle registration document must be produced at the grant of a new vehicle licence. If this is unavailable a V5 slip or proof of purchase providing the date of first registration can be accepted followed by the full V5 within one month of the application being submitted - and following any change to the original document.

Age/Mileage Requirement

- 3.11** All hackney carriage and private hire vehicles will not normally be considered for licensing unless they are under 7 years of age from date of first registration (date as shown on DVLA registration document) and accrued less than 120,000 miles.

Renewal of Vehicle Licences

- 3.12** Once a licence has expired the licence cannot be renewed and any subsequent application will be treated as a new application, unless there are exceptional circumstances. If a licence holder believes there are exceptional circumstances, they must put a request in writing to the licensing team, who will consider whether a renewal will be accepted.

Renewal applications for Hackney Carriages and Private Hire Vehicles will only be granted prior to the 15th anniversary of date of first vehicle registration (date as shown on DVLA V5 registration document) with less than 500,000 miles on the date the licence is renewed.

Vehicles will only be considered for renewal no earlier than one calendar month before the relevant anniversary of the date of first registration of the vehicle. Vehicles past their 15th Anniversary will not be renewed.

- 3.13** Any vehicles presented for licensing that do not meet the above criteria will be refused by authorised officers using delegated powers. Applicants may appeal these decisions to the Magistrates' Court, or in the case of a hackney carriage appeal to the Crown Court.

Exceptions to Age Requirement

- 3.14** Special Event Vehicles are exempt from the general age/mileage policy and fall into the following categories:
- 3.16.1 Executive Vehicles presented for licensing for the first time must not be older than 7 years on the day the application is received.
 - 3.16.2 American Stretch Limousines presented for licensing for the first time must not be older than 7 years on the day the application is received.
 - 3.16.3 Historic Vehicles presented for licensing for the first time must be constructed over 40 years ago. Note: In accordance with DVLA taxation class for Historic Vehicles. Proof of the year the vehicle was built must be provided.

Vehicle Specifications

- 3.15** The vehicle shall have four side opening doors (designed for the purpose of permitting persons access to/from the interior) - any lift-up tailgate shall not be included; or a vehicle shall have three side opening doors (designed for the purpose of permitting persons access to/from the interior) and two rear opening doors (designed for the purpose of permitting persons access to/from the interior).
- 3.16** Any vehicle's suitability for licensing will also be determined by the positioning of its seating, fittings and fixtures for the ingress and egress of passengers and their safety.
- 3.17** Other than a vehicle classed as a special event vehicle the vehicle must be right-hand drive.
- 3.18** The vehicle must have European Community Whole Vehicle Type Approval (ECWVTA), GB Type Approval or UK(NI) Type approval and must show category M1 on the V5C/logbook.
- 3.19** If the requirements in Condition 3.18 above cannot be satisfied, then a Driver and Vehicle Standards Agency (DVSA) Basic Individual Vehicle approval (IVA) or Basic Voluntary Individual Vehicle Approval (VIVA) inspection must be undertaken and a satisfactory report produced.
- 3.20** In the case of a Private Hire vehicle its appearance must not lead people to believe it is a Hackney Carriage Vehicle.
- 3.21** No vehicle will be licensed unless it can accommodate at least four passengers.
- 3.22** The vehicle must have seats with a minimum width of not less than 400mm per person.
- 3.23** The vehicle shall be fitted with appropriate seatbelts to the front and rear seats of the vehicle.
- 3.24** Estate versions of saloon vehicles fitted with seats in the rear luggage compartment will be licensed for a maximum of 4 passengers.

Roof / Boot Racks & Bullbars

- 3.25** No roof racks, boot racks or bullbars may be fitted to licensed vehicles during the currency of the licence.

Carriage of Portable Oxygen Tanks

- 3.26** Hackney carriage/private hire vehicle drivers will accept the carriage of portable oxygen tanks for passengers that require their usage for medical purposes.

Vehicle Testing

3.27 No vehicle shall be first licensed or re-licensed unless the vehicle has passed the vehicle inspection at one of the Borough Council's approved testing stations. Each vehicle inspection shall consist of a DVSA MOT Test and Licensing Authority Compliance Test. The only exceptions to this are for new vehicles under 1 year old or if a valid DVSA MOT certificate has been issued within 14 days of the initial new vehicle licence application.

From the initial issue or first renewal after a vehicle is 5 years old, it will be required to be inspected to the above standards at six monthly intervals.

3.28 The Borough Council will not consider a grant or renewal of a vehicle licence unless it has been examined in accordance with the Borough Council's Hackney Carriage & Private Hire Vehicle Compliance Testing Standards Code of Practice (See Annex D). The Inspection Report must be dated within one calendar month on the day the application is received for a new grant or date of expiry of existing licence for renewal applications.

3.29 Costs of such testing is payable by the person wishing to licence the vehicle. In addition, the history of the vehicle may be taken into consideration when determining whether the vehicle should be licensed.

3.30 Copies of all compliance test certificates required for vehicles over 5 years old (see 3.30 above) are emailed directly to the Licensing Team by the inspector at the testing station. The vehicle proprietor must provide the DVSA MOT certificate to the Licensing team within 72 hours of the test. Tests can be carried out by an approved testing station up to one calendar month before the due date. Failure to have an appropriate test carried out, and/or provide the MOT certificate in accordance with this requirement, may lead to suspension or revocation of the vehicle licence.

3.31 A vehicle which fails an inspection/safety check during the currency of a licence will have the fault(s) rectified and the vehicle re-inspected at the same testing station within 2 months of the original inspection. Minor Failure and Advisory items from the DVSA MOT test (with the exception of windscreen chips and corrosion) must be rectified within 2 months of the original test, and the vehicle re-presented to the same testing station. Failure to comply with the above may lead to the automatic suspension or revocation of the vehicle licence.

3.32 A vehicle may be inspected by an authorised officer of the Borough Council or a Police Officer, at any reasonable time. If the person inspecting the vehicle is not satisfied as to the fitness of the vehicle they may give written notice to the proprietor/operator to make the vehicle available for further inspection and testing at such reasonable time and place as may be specified and the vehicle licence may be suspended until the authorised officer or police officer is so satisfied. If the authorised officer or police officer is not satisfied within two months of the issue of the written notice the Vehicle licence shall be deemed revoked. An authorised officer or police officer may permit other persons to examine the vehicle on their behalf (e.g. DVSA).

Altered Vehicles

3.33 An altered vehicle is any vehicle which has been altered from the original manufacturers specification, re-registered or has been an insurance loss (specified within current government guidelines) and categorised as follows:-

Category A. A vehicle cannot be repaired. Entire vehicle has to be crushed.

Category B. A vehicle cannot be repaired. Body shell has to be crushed, but you can salvage other parts from it.

Category C. Can be repaired, but it would cost more than the vehicle's worth. You can use the vehicle again if it's repaired to a roadworthy condition.

Category D. Can be repaired and would cost less than the vehicle's worth, but other costs (such as transporting your vehicle) take it over the vehicle's value. You can use the vehicle again if it's repaired to a roadworthy condition.

Category N. Can be repaired following non-structural damage. You can use the vehicle again if it's repaired to a roadworthy condition.

Category S. Can be repaired following structural damage. You can use the vehicle again if it's repaired to a roadworthy condition.

3.34 Categories C, D and S only will be considered for licensing if the vehicle has been subjected to a satisfactory Basic IVA or Basic VIVA test (engineers report) from the Driver and Vehicle Standards Agency (DVSA).

3.35 Vehicles without a DVSA engineers report will only be considered for licensing if they have been built to the manufacturer's original specification.

3.36 The IVA test is appropriate for vehicles not previously registered in the UK, and a VIVA for vehicles registered in the UK to prove compliance.

3.37 Category A and B (as defined by the Code of Practice for the Disposal of Motor Vehicle Salvage) write offs will not be considered fit for licensing.

3.38 All vehicles converted or altered to be Wheelchair Accessible will only be considered for licensing upon production of a satisfactory Normal IVA or Normal VIVA test (engineers report) from the Driver and Vehicle Standards Agency (DVSA).

Vehicle Inspections

3.39 All vehicles being presented for testing at the approved Borough Council testing station shall be in a clean condition to allow the tester to inspect the vehicle. The tester may refuse to test a vehicle that does not conform to this requirement.

Exterior Bodywork and Wheel trims

3.40 The bodywork of the vehicle shall be in good condition and shall be as originally fitted by the manufacturer. Wheel trims must be fitted to all road wheels where part of the manufacturer's original specification.

Vehicle Accidents / Damage to Vehicle

- 3.41** The proprietor of a private hire/hackney carriage vehicle must report to the Borough Council (by way of a prescribed accident notification and vehicle damage form) as soon as possible or in any event within 72 hours, any accident or incident which has caused damage to the vehicle or to any other property (i.e. other vehicle, fence post etc). An example of the accident notification and vehicle damage form is attached at Annex A, is also available in hardcopy upon request or can be completed online from the Borough Council's website.
- 3.42** It is not necessary to report a stone chip or other similar very minor damage to a licensed vehicle providing no damage has been caused to a person or property, and the damage would pass a compliance test.

Fire Equipment and First Aid

- 3.43** Where a fire extinguisher is carried in a licensed vehicle, it must be either a 1kg dry powder or a 2 litre AFFF. Fire extinguishers must be maintained in accordance with BS5306 Part 3.
- 3.44** All licensed vehicles must carry a first aid kit The first-aid kit is for self-administration only. The following contents must be presented in a suitable container marked 'First Aid' positioned so that it is readily available for use:
- 20 Sterile Washproof Plasters
 - 2 Sterile Dressings
 - 2 Triangular bandages
 - 10 Moist Wipes
 - 2 Sterile Eye wash Pods
 - 2.5cm Microporous tape
 - 6 Assorted safety pins
 - 2 Self Seal waste bags
 - 1 Pair disposable gloves

Change of Address

- 3.45** The holder of a hackney carriage or private hire vehicle licence shall notify the Borough Council, in writing, of any change in address within 7 days of the change occurring. Failure to do so may result in the issue of penalty points or the matter being referred to a panel of the Licensing & Appeals Board.

Radio devices

- 3.46** No citizen band radios may be fitted in any licensed hackney carriage or private hire vehicle.
- 3.47** No radio scanning devices of whatsoever type or sort may be fitted to, carried in or used in or in the vicinity of any hackney carriage or private hire vehicle during the currency of the licence.

CCTV Cameras

- 3.48** The holder of a hackney carriage or private hire vehicle licence may, subject to the written approval of the Borough Council, install and use a visible closed circuit TV surveillance camera in their vehicles which faces outwards and/or inwards and are for insurance purposes only. The camera must not record audio sound within the vehicle.
- 3.49** There is no requirement to display signage where outward only facing cameras are fitted. Where inward facing cameras are installed written approval will be required from the Licensing Team and the vehicle proprietor will need to be registered with the Information Commissioners Office. Proof of that registration will be required by the Licensing Team. Signage will be required where an inward facing camera has been approved.

Ventilation

- 3.50** All vehicles shall have suitable and adequate ventilation.

Interior

- 3.51** All upholstery shall be clean and in a well maintained condition. No tear, crack, hole or burn will be acceptable other than 'fair, wear & tear'. Upholstery includes seats, headrests, armrests, carpets and other trim. Failure to maintain the interior of a vehicle to these standards may result in the issue of penalty points or referral to a Panel of the Licensing & Appeals Board.
- 3.52** All fittings shall be properly maintained and in good working order. Fittings include clocks, interior lights, sun blinds, door surrounds, grab handles, other equipment provided for passenger comfort and any equipment in, on or forming part of the vehicle including wheelchair ramps and securing fittings where the vehicle is to be licensed to carry wheelchair bound passengers. Failure to maintain these fittings in a good clean working order may result in the issue of penalty points of a referral to a Panel of the Licensing & Appeals Board.
- 3.53** Internal roof and floor coverings must be kept clean and in good condition, with no tears or other damage.

LPG Conversions for existing licensed vehicles

- 3.54** Any vehicle proprietor converting their licensed vehicle to run on Liquid Petroleum Gas (LPG) must notify the Borough Council of such change and comply with the following conditions.
- LPG systems must be fitted in accordance with LPGA Code of Practice 11.
 - That the vehicle displays on the front and rear screens, a sticker stating that the vehicle has been fitted with a LPG tank for the purpose of alerting the emergency services in the event of an accident.
 - If a doughnut tank is fitted in the spare wheel well of the boot, the spare wheel must be securely placed in a position not obstructing the entire luggage space.
 - The proprietor of the vehicle must notify DVLA Swansea of the change in fuel from petrol to both LPG and petrol.

- The vehicle must be annually serviced by a person competent in LPG powered vehicles.

LPG Conversions - New applicants

- 3.55** An applicant for a licence involving a vehicle which has been converted to run on LPG will be required to produce, prior to a licence being issued, a certificate stating that the LPG system has been fitted in accordance with LPGA Code of Practice 11.
- 3.56** The vehicle will be required to undergo an annual service by a person competent in LPG powered vehicles in addition to the Borough Council's Compliance Testing Standards.
- 3.57** If an LPG conversion involves installation of an LPG fuel tank in a vehicle's boot space (and possible relocation of the spare wheel) it shall be a requirement that an amount of space shall remain free for the storage of a reasonable amount of luggage and any spare wheel displaced as a result must be stored in a location that does not impinge on the passenger carrying area of a vehicle.

Tinted Windows

- 3.58** Tinted windows must comply with the Road Vehicles (Construction & Use) Regulations which specify the minimum levels of light that must pass through the windscreen and front side windows. The limits are:
- The light transmitted through the windscreen must be at least 75%; and
 - The front side windows must allow at least 70% of light to be transmitted through them.

Unfit Vehicle Notices

- 3.59** Unfit Vehicle notices can be issued by Authorised Officers and Police Officers where vehicle defects give cause for concern.
- 3.60** Immediate Unfit Notices will be given if the vehicle appears to be unsafe to carry members of the public. Once a Notice is issued the vehicle must not be used for hire with immediate effect. The vehicle must be presented to either an officer or the Borough Councils approved testing station with the faults rectified. Only after this will the Notice be lifted and the vehicle can then be used for hire.
- 3.61** If the Notice is not lifted within two-months, the vehicle licence will be deemed revoked.
- 3.62** Deferred Notices can be issued which means the vehicle can continue to be used for the time specified and the faults rectified within a specified time. When the faults are rectified the vehicle must be presented to a Borough Council approved testing station for inspection.

Advertising on outside of vehicle

3.63 The Borough Council will allow advertisements to be placed upon a vehicle subject to the following:

- The proprietor of a licensed vehicle shall not display or permit to be displayed on the vehicle any sign or advertisement whatsoever unless written permission has been obtained from the Borough Council.
- Advertising is to be limited to the back door panels of licensed vehicles only. Advertising on parts of the vehicle in addition to the back door panels may be considered but only after prior written approval of the Borough Council has been given. However, no advertising will be permitted on the windows of the vehicle.
- All advertisements shall comply with the British Code of Advertising Practice and shall be in a form acceptable to the Advertising Standards Authority. The Borough Council reserves the right to require the licensee to withdraw from display any advertisement that may be considered inaccurate, misleading, unlawful, defamatory, in bad taste or of an unacceptable standard.
- No advertisement will be permitted that relates to or advertises alcohol, nudity, gambling, smoking materials or others of a political nature.
- The same advertising must be displayed on the nearside and offside doors of vehicles.
- Advertising must be permanently fixed to the vehicle, magnetic and other removable medias are not permitted.
- Any advertising may cover both back doors.
- Advertising may not be stuck over door trims. Door trims may not be removed to accommodate advertising.

3.64 In the case of Private Hire Vehicles advertising is subject to the specific exclusion of the words "taxi", "cab" or "hire" the use of which will not be permitted. The Borough Council reserves the right to withdraw from display any advertisement that may be considered inaccurate, misleading, unlawful, defamatory, in bad taste or of an unacceptable standard.

Vehicle Identification

External Licence Plate

3.65 The vehicle licence plate shall be securely fixed and displayed outside and on the rear of the vehicle and shall be clearly visible during daylight hours from a distance of not less than 5 metres. The licence plate must not obstruct any signage prescribed by the Borough Council or any lights or the vehicles registration mark. Any items, such as towbars must not obstruct the licence plate. The plate must be maintained in a good, clean condition at all times. If there is any deterioration to the licence plate, the driver must report it immediately to the Vehicle Proprietor and the Licensing Team.

3.66 The licence plate shall be displayed in a vertical position and firmly fixed to the outside of the vehicle at the rear. The plate must be prominently displayed as to be readily visible to members of the public and that the figures and numbers endorsed thereon are distinct and legible.

- 3.67** The licence plate is the property of The Borough Council to whom it must be returned within 7 days of demand if the licence is suspended, revoked, not renewed for any reason or following the sale of the vehicle. Authorised officers are entitled to physically remove the plate from the vehicle and retain it where necessary.

Internal Licence

- 3.68** The internal vehicle licence shall be fixed and displayed inside the front windscreen on the passenger side of the vehicle in the bottom corner and must not be obstructed.

Reporting a Lost, Damaged or Stolen Licence Plate

- 3.69** The vehicle proprietor/licensee shall inform the Borough Council within 72 hours should the licence plate become lost, damaged or stolen. If lost or stolen, the matter shall be reported to the police and a relevant reference number shall be required (i.e. Crime Number or Lost Property reference).

List of drivers to be maintained

- 3.70** The vehicle proprietor/licensee shall maintain a list of names and addresses of all persons that have use of that licensed vehicle. The list shall be made available to authorised officers upon request.

Trailers attached to Licensed Vehicles

- 3.71** The proprietor of a licensed vehicle may attach a trailer for carrying luggage when required, subject to the completion of the relevant application, and providing that an external trailer licence plate is affixed to the rear of the trailer. The licence plate must be the same as the vehicle licence plate, with the addition of a trailer identification mark.

- Trailers cannot be used by Hackney Carriage vehicles when plying for hire on a Hackney Carriage Stand.
- The trailer must at all times comply with all Road Traffic legislation requirements, in particular those laid down in the Road Vehicles (Construction and use) Regulations 1986

- 3.72** Trailers must comply with the following standards:

- Unbraked trailers shall be less than 750kg gross weight;
- Trailers over 750kg gross weight shall be braked acting on at least 2 road wheels;
- The towing vehicle must have a kerb weight at least twice the gross weight of the trailer;
- A suitable lid or other approved means of enclosure shall be fitted to secure the contents within the trailer whenever in use;
- The maximum permissible length of the trailer shall be 7 metres including the drawbar and coupling;
- The width of the trailer shall not be greater than the towing vehicle subject to no trailer being wider than 2.3 metres;
- The maximum length for braked axle trailers is 5.54 metres.

Change of Use

- 3.73** Once a Hackney Carriage or Private Hire vehicle (excluding special event vehicles) has been licensed it will not be considered as a new application if a change of use between hackney carriage and private hire is requested, or if the licence has previously lapsed and is being re-instated. This is conditional that on the date the licence is issued the vehicle held a vehicle licence issued by this authority in the preceding 3 months which has not been revoked.

Transfer of Vehicle

- 3.74** If a proprietor of a licensed hackney carriage vehicle or holder of a private hire vehicle licence transfers his interest, in whole or in part, in the vehicle to any other person not specified in the vehicle licence he must notify the Borough Council within 14 days using the appropriate transfer form. The form must be accompanied by the fee and supporting documents.

Alteration of Vehicle

- 3.75** During the currency of the licence, no material alteration or change in the specification, design, condition or appearance of the vehicle shall be made without the prior written approval of the Borough Council. All vehicles must have four doors with the exception of purpose built vehicles.

Passengers

- 3.76** The proprietor or owner of a licensed hackney carriage or licence holder of a private hire vehicle shall not permit to be conveyed in the vehicle a greater number of persons than prescribed on the licence for the vehicle.
- 3.77** The driver of a licensed hackney carriage or private hire vehicle shall not, without the consent of the hirer of the vehicle, convey or permit to be conveyed any other person in the vehicle.
- 3.78** A driver shall not refuse to carry fewer persons than the number marked on the licence plate.

4.0 Hackney Carriage Vehicles

- 4.1** The following are conditions attached to the hackney carriage vehicle licence. These conditions are additional to the requirements imposed upon proprietors by the Town Police Clauses Act 1847 and the Local Government (Miscellaneous Provisions) Act 1976. Breach of any of these conditions may lead to suspension or revocation of the licence and/or prosecution. These conditions are equally applicable when the hackney carriage is being used for private hire purposes.

Restriction on Numbers of Licensed Vehicles

- 4.2** The Borough Council does not restrict the number of hackney carriage licences that it issues. Licence numbers 1 to 52 may be saloon vehicles but any additional hackney licenses issued, i.e. plate 53 onwards must be wheelchair accessible and meet the Borough Council's age/mileage policies.

Intended Use

- 4.3** Applicants for new and renewal hackney carriage vehicle licences will be required to demonstrate a bona fide intention to ply for hire predominantly in the Borough Council of King's Lynn and West Norfolk area. Applicants who do not intend to a material extent to ply for hire within the Borough Council of King's Lynn and West Norfolk area may not be granted a hackney carriage vehicle licence.

Wheelchair Accessible Vehicle Specifications

- 4.4** All wheelchair accessible vehicles shall be properly equipped with properly mounted fittings for the safe securing of a wheelchair and a passenger seated in it, when carried in the vehicle.
- 4.5** If a mechanical hoist is fitted to the vehicle this will be required to be inspected annually by the manufacturer or his approved agent and a certificate produced to that effect.
- 4.6** Any vehicle licensed as wheelchair accessible must remain so at all times while licensed. Additional seats which cannot be stowed to allow immediate carriage of a wheelchair passenger must not be fitted.

Wheelchair Occupant Space

- 4.7 A wheelchair space shall not be less than:
- 1200mm measured in the longitudinal plane of the vehicle;
 - 750mm measured in the transverse plane of the vehicle;
 - 1350mm measured vertically from any part of the floor of the wheelchair space;

A wheelchair space shall allow the carriage of a wheelchair and a wheelchair user.

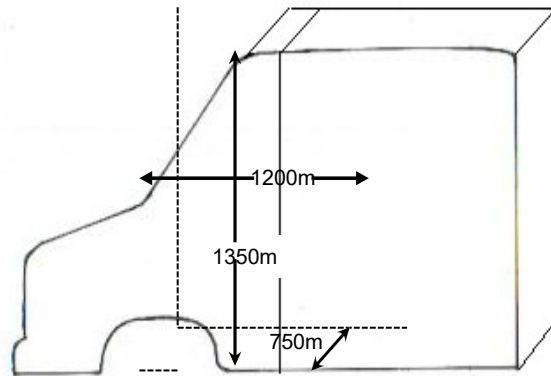

Lifts/Ramps

- 4.8 Access to the vehicle must be possible from the road or pavement either by a lift or ramp. Any power-operated device must be capable of manual operation in the event of a power failure. The boarding device must have a safe working load of 300kg and operate under normal loading conditions without undue deflection.

Ramps

- 4.9 A ramp should be of slip resistance material and at least 750mm in width. Dual channel ramp designs are not accepted. The ramp should be capable of being deployed both onto the road and onto a 125mm high kerb. The ramp when deployed should be securely located at the point of entry to the vehicle. For side loading the ramp when deployed to the pavement should not exceed a slope of 1:4. For rear loading the ramp when deployed to the road should not exceed 1:4. When not in use the ramp should be securely stored in such a manner as not to block any of the vehicle doors and not to present a hazard to the vehicle occupants.

Lifts

- 4.10 The lift platform must be not less than 750mm in width and not less than 1200mm in length. The platform should be equipped with a device to prevent the wheelchair rolling off and should operate at a vertical speed of less than 0.15m/s.

Wheelchair securing mechanism anchorage

- 4.11 A 4 point anchorage system must be fitted, comprising two for attachment at the front of the wheelchair and two at the rear of the wheelchair, in accordance with ISO 10542-2.

Wheelchair securing mechanism

- 4.12** A suitable securing mechanism must be provided to secure the wheelchair in position and the wheelchair should be locked in place before the journey commences. The occupant of the wheelchair must be provided with an occupant restraining system (seatbelt).

Taximeters

- 4.13** All Hackney Carriage vehicles licensed or to be licensed shall have a taximeter fitted. Each taximeter shall be tested by one of the Borough Council's approved testing stations in order to establish that the meter reflects the current fares as prescribed in the Hackney Carriage Fare Tariff approved by the Borough Council.
- 4.14** The taximeter shall be placed in a safe position and so far as possible so that all letters and figures on the face thereof shall be at all times plainly visible to any persons being conveyed in the carriage. For that purpose, the letter and figures shall be capable of being suitably illuminated during the period of hiring.
- 4.15** The driver of a hackney carriage shall, at the commencement of the journey, activate the meter so that the word 'Hired' is clearly visible and shall keep the meter operating until the termination of the hiring – 'Commencement of the journey' means:
- When the hirer enters the vehicle.
 - In the case of a wheelchair bound passenger, when the wheelchair & passenger have been securely loaded into the vehicle.
 - When the driver has attended at an appointed place, and has made his presence known to the hirer.
 - When the driver has presented themselves at an appointed place at a specified time.
- 4.16** The driver of a Hackney Carriage Vehicle shall, when standing or plying for hire, keep the taximeter locked in the position in which no fare is recorded on the face of the taximeter and operate a sign, which shall bare the words 'For Hire' in clear legible letters.
- 4.17** Any taximeter fitted to a Hackney Carriage Vehicle, which has been adjusted or repaired shall have the taximeter retested by one of the Borough Council's approved testing stations.
- 4.18** The taximeter shall clearly display a fare not exceeding the rate or fare approved by the Borough Council.
- 4.19** The taximeter and all the fitting thereof shall be affixed to the carriage with security seals or other appliances that it shall not be practicable for any person to tamper with them except by breaking, damaging or permanently disabling the security seals.
- 4.20** The taximeter must not be running whilst carrying out any of the duties described in Condition 7.40 (Equalities Act 2010).

Inspection of Taxi Meter

- 4.21** A taxi meter fitted to a licensed vehicle may be inspected by an authorised officer of the Borough Council or by a Police Officer at all reasonable times.
- 4.22** If the officer or constable inspecting the vehicle is not satisfied as to the accuracy of the meter, he may without prejudice to the taxi meter condition, give written notice to the proprietor to make the taxi meter available for further inspection and testing at such reasonable time and place as may be specified, and the vehicle licence may be suspended until the officer or constable is satisfied as to the vehicles fitness or as to the accuracy of the taxi meter.
- 4.23** If the officer or constable is not so satisfied within two months of the initial inspection, the Hackney Carriage Licence shall be deemed revoked.

Roof Signs

- 4.24** All Hackney Carriage vehicles must be fitted with a roof-mounted sign.
- 4.25** Roof signs fitted upon a Hackney Carriage Vehicle must be white in colour and shall be securely fitted to the vehicle. The sign shall be of a uniform height of not less than 110mm and not more than 228mm. The length of the roof sign must not be less than 240mm or greater than 482mm. Roof signs must be of a design and shape approved by the Borough Council.
- 4.26** All Hackney Carriage Vehicle roof signs shall display the wording 'TAXI' on the front. The sign shall be capable of being illuminated internally in such a manner that the word 'TAXI' is illuminated at all times when the vehicle is plying for hire, but not otherwise.
- 4.27** All wording shall be black in colour and the word 'TAXI' must not be less than 65mm in height.
- 4.28** Proprietors of purpose built vehicles with built in roof signs may apply in writing to the Borough Council to request a departure from conditions 4.24 and 4.26 above.

Unattended Taxis

- 4.29** No Hackney Carriage may be left on a taxi rank designated by Section 64 of the Local Government (Miscellaneous Provisions) Act 1976 or a Local Traffic Order without a licensed driver in attendance to take care of it whilst plying for hire.

5.0 Private Hire Vehicles

Vehicle Signage

- 5.1 The private hire vehicle shall not display any sign, which consists of or includes the word 'Taxi' or 'Cab' whether singular or plural, or 'Hire', or any word of a similar meaning or appearance to any of those words, whether alone or as part of another word. The only exceptions are:
- 5.1.1 The word 'Hire' displayed on a private hire vehicle is when the word is used in conjunction with the word 'Private' to form the term 'Private Hire'.
- 5.1.2 To meet the requirements of Condition 5.3 below.
- 5.2 A sign must be displayed in a prominent position on each front side door of the vehicle displaying either:
- 5.2.1 Borough Council logo with the wording 'Pre-Booked Only insurance invalid unless booked with an operator', or
- 5.2.2 Borough Council logo and specifying the operator name, telephone number for bookings, with the wording 'Pre-Booked Only'
- 5.3 The sign must be in either of the prescribed formats (see example 'A' and 'B' below) and must be affixed to the vehicle by a Borough Council authorised sign maker. Removable signs e.g. magnetic will not be permitted. The signage is only obtainable via the licensing team and must be fitted within 14 days of the date the signage is ready and available with the signage company. Examples of permitted private hire signage:

Example A



Example B



- 5.4** In the event that a private hire vehicle changes private hire operator and the vehicle bears signage in the form of 'Example B' above then new signage will be required. This must be ordered through the Borough Council within 7 days of the change taking place. As 'Example A' does not identify the operator then no change of signage will be required on change of operator.

Roof Signs

- 5.5** Under no circumstances will the Borough Council permit a private hire vehicle to be fitted with a roof-mounted sign of any kind.

6.0 Special Event Vehicles

Application in Writing

6.1 Any person wishing to apply for a special event vehicle licence will be required to apply in writing to the Environmental Health Manager (Commercial) stating the type of vehicle, and age, which they intend to use and the reasons why they believe that they should be considered for this vehicle category. Vehicles issued with a special event licence shall only be used for special occasions and executive business contracts. Vehicles licensed within this category shall not be used for everyday private hire use, e.g. 'school contracts' but must work under the control of a private hire operator.

Sale of Alcohol

6.2 The licensee shall not facilitate the sale of alcohol unless there is in force an appropriate authorisation under the Licensing Act 2003 (either a premises licence or temporary event notice) permitting the sale of alcohol.

Types of Vehicle

6.3 Special event vehicles are a type of private hire vehicle and fall into one of the following categories:

- Executive Vehicles;
- Novelty Vehicles
- Stretched Limousines;
- Historic Vehicles

Age Requirements

6.4 Executive Vehicles presented for licensing for the first time should not normally be older than 7 years on the day the application is received.

6.5 Stretch Limousines presented for licensing for the first time should not normally be older than 7 years on the day the application is received.

6.6 Historic Vehicles presented for licensing for the first time must be constructed over 40 years ago. Note: In accordance with DVLA taxation class for Historic Vehicles.

Licence Plate

6.7 The vehicle licence plate will be required to be fixed to the inside of the boot lid on the vehicle.

Communication Equipment

6.8 No vehicle shall be fitted with a two-way radio system.

Dress Code

6.9 Drivers of special event vehicles will be required to observe a 'smart casual' dress code e.g. no jeans, no t-shirts, no sportswear etc.

Minimum Booking Fee

- 6.10** Vehicles shall not be offered for hire for less than a £30 minimum- booking fee. A receipt must be given to the customer in all cases, unless covered by a contract and receipts and contracts should be available to authorised officers of the Borough Council for inspection;

Stretched Limousines

- 6.11** A “stretched limousine”, is a saloon type vehicle that has undergone an increase in length by extending the wheelbase after manufacture. An “American stretched limousine” is a stretched limousine imported from the USA and typically will have been manufactured originally by Lincoln (Ford) or Cadillac.

- 6.12** The purpose of this Policy and subsequent conditions is to protect public safety. The conditions will apply in addition to the Borough Council’s standard conditions for private hire vehicles and take account of the fact that stretched limousines will:

- travel generally at slower speeds than normal taxis;
- not normally overtake other vehicles;
- be easily recognisable by the hirer;
- be heavier and considerably longer than standard cars;
- be adapted or converted by someone other than the original manufacturer.

- 6.13** For the purposes of calculating the seating capacity of a vehicle the minimum width of a passenger seat is 400mm (16 inches). In the case of an ‘L’ shaped seat, sufficient space must be made available in the corner to prevent the passenger on one side of the corner encroaching on the passenger on the other side.

- 6.14** In the case of a stretched limousine, or an American stretched limousine, where the vehicle has been constructed or adapted to seat up to 8 passengers, originals of the following documentation will be required by the Borough Council before an initial application for a vehicle licence can be considered:

- Completed importation documentation where applicable and individual vehicle approval (IVA) or Voluntary Individual Vehicle Approval (VIVA) certificate.
- Proof the ‘stretch’ was performed by the manufacturer or by a Coachbuilder approved by the vehicle manufacturer i.e. American Limousines must have been built by an approved coachbuilder under the QVM programme for Ford Vehicles or the CMC programme for Cadillac Vehicles.
- DVLA Registration Document (V5).
- Valid Certificate of Insurance, with cover for hire and reward.
- Current MOT certificate issued by an approved Testing Station.
- Where applicable, an installation certificate from a Liquefied Petroleum Gas Association (LPGA) Approved UK Vehicle Conversion Company, in the case of vehicles converted to run on LPG.
- Valid Road Vehicle Excise licence.

Replacement Parts

- 6.15** Any replacement parts fitted to stretch limousine vehicles must meet the approved standards of the stretched specifications i.e. tyres will not only have to meet the size specifications, but must also meet the weight specification.

Private Hire Operator – Additional Requirement

- 6.16** Special event vehicles must be specifically requested by the customer and it is not for the operator to determine which class of vehicle should be assigned to the booking. In addition to the private hire operator records required under paragraph 8, operators of special event vehicles are to maintain a record of the nature of the special event i.e. why the customer requested a special event vehicle.

7.0 Combined Hackney Carriage & Private Hire Driver's Licences

7.1 The grant or renewal of a combined driver's licence shall meet the following requirements:

7.1.1 All applicants/Drivers must be in possession of a full driving licence issued by the DVLA or a licence from an EEA or EU state and that licence must have been in place, for at least, the preceding 12 months.

7.1.2 A medical will be required upon initial application and must be carried out by a registered Medical Practitioner to group 2 DVLA standards using the Borough Council's approved form. Subsequent medicals will be required at age 45, then every five years after the age of 45 and then annually from the age of 65 years. A driver under the age of 65 with a controlled medical condition may also be required to undergo a full medical annually.

7.1.3 Any changes to an applicant's health between the date of the medical certificate and issue of the licence must be notified to the Borough Council in accordance with condition 7.4.

7.1.4 A DVLA Check code will be required with a new application and annually thereafter. This allows the Borough Council to access your driving record online from the DVLA's website.

7.1.5 A DBS Disclosure to enhanced level showing the occupation as "Other workforce Taxi/Private Hire Driver" shall be required on first grant and licence holders are required to subscribe to the DBS online 'Update Service'. A DBS check will be carried out by the Borough Council every six months via the DBS 'Update Service'. A new DBS disclosure will be required if the 'Update Service' revealed additional matters or the subscription to the update service has lapsed.

7.1.6 Any applicant must make a declaration (by means of a form or questionnaire provided for the purpose) as to any criminal or motoring convictions recorded or pending against them in order to confirm that the applicant is a fit and proper person to hold a licence.

7.1.7 Any convictions received by or notified to the applicant between the date of application and issue of the licence, must be disclosed to the Borough Council in accordance with condition 7.16.

7.1.8 The applicant must have a right to work in the UK.

7.1.9 All new applicants are required to pass a driving standards assessment set to the former DSA standard. Evidence of this must be supplied to the Borough Council.

7.1.10 All new applicants are required to pass the Borough Council's knowledge test in accordance with conditions 2.14 to 2.16.

7.1.11 Applicants for renewal must supply a valid HMRC check code to show they are registered for income tax.

- 7.2** The DVLA driving licence must cover the appropriate category for the vehicle being driven.
- 7.3** An authorised officer of the Borough Council may, upon reasonable request ask for a driver to undergo a medical at any time.
- 7.4** If a medical certificate is not produced when requested, the Borough Council may consider suspension/revocation of a Drivers licence. If a licensed driver is diagnosed with any medical condition that requires treatment or regular medication, they must notify the Licensing Team as soon as possible or no longer than 72 hours after the change in circumstances.
- 7.5** In relation to the consideration of convictions and cautions recorded against persons the Borough Council has adopted the policy set out in Annex B (Guidelines relating to the relevance of convictions).
- 7.6** A Combined Driver's Licence shall be valid for a maximum term of three years (unless a shorter period is appropriate). Applicants requiring a shorter licence period must apply in writing stating full reasons why a lesser period is appropriate.
- 7.7** Notwithstanding Condition 7.6 the expiry date of a combined driver's licence will not be later than the expiry date of the photograph on a DVLA licence.
- 7.8** If a driver accrues 9 or more points in a 3 year period on their DVLA driving licence, they will be required to appear before a panel of the Licensing & Appeals Board in order for their continued suitability to hold a driver's licence to be assessed.
- 7.9** Any driver who receives, during the currency of their licence, a conviction for drink driving will automatically have their suitability to hold a licence referred before a Panel of the Licensing & Appeals Board for consideration of revocation of their licence.
- 7.10** The driver of a private hire vehicle while driving or in charge of such a vehicle shall not:
- 7.10.1** tout or solicit or cause or procure any other person to tout or solicit on a road or other public place any person to hire or to be carried for hire in any vehicle;
 - 7.10.2** ply for hire by offering a vehicle for immediate hire while they or that vehicle are on a road or other public place;
 - 7.10.3** accept an offer for the immediate hire of a vehicle while they or that vehicle are on a road or other public place except where the offer is first communicated to the driver in person by telephone or vehicle radio without him / her in any way procuring the offer.
 - 7.10.4** In this condition "road" means any highway and any other road to which the public has access and includes bridges over which a road passes.
- 7.11** When hired to drive to a particular destination, a driver shall (subject to any directions given by the hirer) proceed to that destination by the shortest available route.

Conduct of Driver

7.12 The driver shall at all times:

- 7.12.1** carry a reasonable quantity of luggage when requested by any person hiring or seeking to hire a vehicle, and afford all reasonable assistance in loading and unloading passengers' luggage.
- 7.12.2** be clean and respectable in his/her dress and person and behave in a civil and orderly manner.
- 7.12.3** take all reasonable steps to ensure the safety of passengers conveyed in, entering or alighting from the vehicle driven by him/her.
- 7.12.4** not without the express consent of the hirer play any radio or sound reproducing instrument or equipment in the vehicle other than for the purpose of sending or receiving messages in connection with the operation of the vehicle.
- 7.12.5** not cause or permit the noise emitted by any radio or other previously mentioned equipment in the vehicle which he/she is driving to be a source of nuisance or annoyance to any person, whether inside or outside the vehicle.
- 7.12.6** when collecting passengers, the driver will not sound the vehicle's horn but shall make their arrival known in person.

Vehicle Checklist

7.13 Each driver must carry out a daily walkaround check of the vehicle before first use. The check should include all of the items on the vehicle checklist form at Annex E.

Change of Address

7.14 The driver shall notify the Borough Council in writing of any change of his/her address during the period of the licence within seven days of the change taking place.

Change of Operator

7.15 The driver shall notify the Borough Council in writing of any change in the private hire operator he/she is working under the control of within 7 days of the change taking place. If the change requires new private hire vehicle signage then please refer to Condition 5.1.

Convictions, Cautions, Driving Offences, Arrests & Charges etc.

7.16 The driver shall notify the Borough Council in writing if he/she is arrested, released on bail, receives any summons, charge, conviction, caution, formal or informal notice, County Court Judgement or fixed penalty notice within 48 hours of receiving such. The written notification should include the following details:

- Offence / alleged offence;
- Date, place & time of offence/alleged offence;
- Whether acting as a hackney/private hire;
- If motoring offence:
 - whether paying passengers carried;
 - speed or alleged speed;
 - speed limit for road;
 - Punishment e.g. amount of fine, number of penalty points issued etc.
 - whether speed awareness course undertaken

7.17 Depending on the circumstances or the number of penalty points accrued on their DVLA driver's licence, drivers may be referred to a Panel of the Licensing & Appeals Board. In doing so, the Panel must have regard to all convictions, police cautions, charges, driving convictions, complaints of unacceptable conduct/behaviour, breach of licence conditions and other convictions obtained during the course of a Licence.

7.18 Drivers should be aware that if they fail to comply with this requirement, it may prevent the Borough Council from renewing their driver's licence under delegated authority.

7.19 In the event of a disqualification from driving, a driver shall immediately inform the Borough Council and return their driver's badge.

Badges

7.20 The driver shall at all times, whilst in charge of a licensed vehicle, wear their badge on their person where it is clearly visible.

7.21 A driver shall not damage or deface a driver's badge nor allow any other person to do so.

DVLA Driving licence

7.22 A driver shall produce their DVLA driving licence for inspection by an authorised officer as part of an application for the grant or renewal of a combined drivers licence or at any other time upon request (within 7 days of request).

Prompt Attendance

7.23 The driver of a vehicle shall, if they are aware that the vehicle has been hired to be in attendance at an appointed time and place or they have otherwise been instructed by the operator or proprietor of the vehicle to be in attendance at an appointed time and place (unless delayed or prevented by sufficient cause) punctually attend at that appointed time and place.

Passengers

7.24 The driver shall not convey or permit to be conveyed in a vehicle a greater number of persons than that prescribed in the licence for the vehicle.

- 7.25** The driver shall not without the consent of the hirer of a vehicle convey or permit to be conveyed any other person in that vehicle.
- 7.26** The driver, who shall knowingly convey in a vehicle the dead body of any person, shall immediately thereafter notify the fact to the Licensing Team.
- 7.27** No driver without reasonable excuse shall refuse to carry or refuse assistance to any person with a disability or refuse to carry an assistance dog (without the appropriate exemption certificate).
- 7.28** No extra fee may be charged for carrying an assistance dog or wheelchair.

Lost Property / Misplaced Articles

- 7.29** The driver shall immediately after the termination of any hiring of a vehicle or as soon as practicable thereafter carefully search the vehicle for any property which may have been accidentally left there.
- 7.30** If any property accidentally left in a vehicle by any person who may have been conveyed therein is found by or handed to the driver, it shall be taken as soon as possible and in any event within twenty-four hours (if not claimed by or on behalf of its owner) to a convenient police station and left in the custody of the officer in charge after obtaining a receipt for it.

Animals

- 7.31** The driver shall not convey in a vehicle any animal belonging to or in the custody of himself or the proprietor or operator of the vehicle.
- 7.32** The driver shall ensure that any animal belonging to or in the custody of any passenger is conveyed in the rear of the vehicle except that an assistance dog accompanying a disabled person may sit in the front of the vehicle provided that the animal is properly trained to sit in the foot well of the vehicle with the disabled passenger.

Breakdowns

- 7.33** In the event of a breakdown during a hiring, the driver shall ensure that alternative arrangements are made for passengers to continue their journey.

Fare to be demanded

- 7.34** The driver shall not demand from any hirer of a vehicle a fare in excess of any previously agreed for that hiring between the hirer and the operator.

Written Receipts

- 7.35** The driver shall if requested by the hirer of a vehicle provide him with a written receipt for the fare paid.

Passenger Transport Badge Holders

- 7.36** If a licensed driver holds a badge with a County Council to carry passengers on school or other contracts, and that badge is suspended or revoked by the County Council, the driver shall notify the Borough Council, in writing, within 72 hours.

Smoking and Electronic Cigarettes

- 7.37** It is an offence to smoke or permit a person to smoke in a licensed vehicle at any time, even when being used for purposes other than a paid hiring.

- 7.38** The use of Electronic Cigarettes (e-cigs), Personal Vaporizers (PV) and Electronic Nicotine Delivery Systems (ENDS) is prohibited whilst carrying fare-paying passengers.

Failure to provide Information

- 7.39** It is the driver's responsibility to provide the following information throughout the term of their licence:

- DBS check every 6 months in accordance with condition 7.1.4; (unless prescribed to the online update service)
- Annual DVLA check in accordance with conditions 2.12 & 7.1.3;
- Medical Certificate in accordance with condition 2.11;
- Annual disclosure of convictions.

Failure to provide this information throughout the term of the licence may result in the suspension of the driver's licence by officers under delegated authority.

Equalities Act 2010

- 7.40** Section 164A of the Equality Act sets out the duties placed on all drivers of hackney carriage and private hire vehicles. The duties are:

- 7.40.1** if the passenger is in or has with them a wheelchair, to carry the wheelchair;
- 7.40.2** if the passenger has with them any mobility aids, to carry the mobility aids;
- 7.40.3** to take such steps as are necessary to ensure that the passenger is carried in safety and reasonable comfort;
- 7.40.4** to give the passenger such mobility assistance as is reasonably required; and
- 7.40.5** Not to make, or propose to make, any additional charge for complying with a duty mentioned in conditions 7.41.1 to 7.41.4.

- 7.41** Section 165 of the Equality Act sets out additional duties placed on drivers of designated wheelchair accessible hackney carriage and private hire vehicles. The duties are:

- 7.41.1** to carry the passenger while in the wheelchair;
- 7.41.2** not to make any additional charge for doing so;
- 7.41.3** if the passenger chooses to sit in a passenger seat to carry the wheelchair;
- 7.41.4** to take such steps as are necessary to ensure that the passenger is carried in safety and reasonable comfort; and
- 7.41.5** to give the passenger such mobility assistance as is reasonably required.

- 7.42** For the purpose of Condition 7.41.4 and 7.42.5 mobility assistance is defined as assistance:
- 7.42.1** To enable the passenger to get into or out of the vehicle;
 - 7.42.2** If the passenger wishes to remain in the wheelchair, to enable the passenger to get into and out of the vehicle while in the wheelchair where applicable;
 - 7.42.3** To load the passenger's luggage into or out of the vehicle;
 - 7.42.4** If the passenger does not wish to remain in the wheelchair, to load the wheelchair into or out of the vehicle.
- 7.43** Section 168 of the equality act sets out the duties placed on all drivers of hackney carriage and private hire vehicles in respect of assistance dogs. The duties are:
- 7.43.1** To carry the disabled person's dog and allow it to remain with that person,
 - 7.43.2** Not to make any additional charge for doing so
- 7.44** In the case of hackney carriages, the taximeter must not be running whilst carrying out any of the duties described above.

8.0 Private Hire Operators

- 8.1** A Private Hire Operators Licence shall be valid for a maximum period of five years (unless a shorter period is appropriate). Applicants requiring a shorter licence period must apply in writing stating full reasons why a lesser period is appropriate. The Borough Council will only grant operators licences to operators operating from an address within the area of the Borough Council's District.
- 8.2** The applicant for the grant of a new licence will need to obtain a DBS disclosure to basic level as an aid to establishing if an applicant is a suitable person to hold an operator's licence. Note: This is not required where a driver's licence is already held and a DBS has been provided to enhanced level.
- 8.3** The applicant must make a declaration (by means of a form or questionnaire provided for the purpose) as to any criminal or motoring convictions recorded or pending against him/her in order to confirm that the applicant is a fit and proper person to hold a licence.
- 8.4** An Operator must not include in his trading title any reference to "taxi" or "cab" unless he/she is also the proprietor of a hackney carriage vehicle.
- 8.5** An Operator must ensure that all vehicles and drivers working for them are licensed by the Borough Council.
- 8.6** When a new driver begins to work under the control of an operator, and when an existing driver leaves, the operator must inform the Borough Council in writing of that change within 7 days.
- 8.7** An Operator must keep records of bookings and produce these to an authorised officer or police officer on request. The content of these will be as prescribed by the Borough Council.
- 8.8** The Operator's licence must be produced on request of an authorised officer or police officer on request.
- 8.9** An operator must, if possible, accept a booking for a Private Hire vehicle if the booking is requested by or on behalf of a disabled person, or a person who wishes a disabled person to accompany him/her.
- 8.10** An operator cannot make an additional charge for the carriage of an assistance dog.

- 8.11** An Operator shall record details of every private hire booking made by them. The following information shall be recorded in an easily retrievable method (e.g. computer database or page numbered log) before the commencement of each journey, and shall include the following:
- the date and time of each booking;
 - how the booking was received, i.e. telephone or personal call;
 - the time of pick-up;
 - where journey was from and to;
 - the name, address and contact telephone number of the hirer;
 - the private hire vehicle licence plate and vehicle registration number of the vehicle allocated the booking;
 - the name of the driver allocated the booking;
 - the name of the individual that responded to the booking request;
 - the name of the individual that despatched the vehicle;
- 8.12** In addition to the requirement of Condition 8.11 above, an operator of a special event vehicle must also record the nature of the special event i.e. why was a special event vehicle booked
- 8.13** The records shall be kept for a period of six months, or such longer period as is required by an Authorised Officer of the Borough Council.
- 8.14** The records shall be produced, on request, to any Police Officer or Authorised Officer of the Borough Council.
- 8.15** An Operator shall maintain at his premises details of all vehicles operated by him, which shall include the following:
- the Private Hire licence plate number;
 - the vehicle registration number;
 - the name and address of the proprietor of the vehicle;
 - the name(s) and address(es) of the driver(s) of the vehicles(s);
 - the badge number(s) of the driver(s).
- The above records shall be produced on request to any authorised officer of the Borough Council or Police Officer.
- 8.16** No operator shall invite or accept a private hire vehicle booking or control or arrange a journey to be undertaken by a private hire vehicle without first making available the charge for the hire of the vehicle to the person making the booking. The charge can be notified in writing or verbally.
- 8.17** The operator shall provide a prompt, efficient and reliable service to members of the public at all reasonable times. This includes the following:
- 8.17.1 Ensure that when a private hire vehicle has been hired to attend at an appointed time and place, the vehicle shall, unless delayed or prevented by sufficient cause, attend punctually at the appointed time and place.
 - 8.17.2 Keep clean, adequately heated, ventilated and lit any premises which the operator provides to which the public have access, whether for the purpose of booking or waiting.
 - 8.17.3 Ensure that any waiting area provided by the operator has adequate seating facilities.
 - 8.17.4 Ensure that any telephone facilities and radio equipment provided are maintained in a sound condition and that any defects are repaired promptly.

- 8.18** An Operator shall undertake to ensure that all drivers and vehicles owned, controlled or operated by them shall be licensed and comply with all the conditions of their driver's licence and / or Private Hire Vehicle licence.
- 8.19** The Equality Act 2010 makes it an offence for a private hire operator to fail or refuse to take a booking for a private hire vehicle;
- if the booking is requested by or on behalf of a disabled person, or a person who wishes a disabled person to accompany him; and
 - the reason for the failure or refusal is that the disabled person will be accompanied by his assistance dog.

This is subject to medical exemption certificates and it is also an offence for the operator to make any additional charge as a result of the need to carry an assistance dog.

Complaints

- 8.20** An Operator shall maintain a log detailing any complaints received from customers. This shall be available for inspection by any authorised officer or police officer upon request. The log must provide the complainant's name/address/complaint details & any action taken against driver/vehicle proprietor.

Change of Address

- 8.21** The operator shall notify the Borough Council in writing of any change of his address (including any address from which he operates or otherwise conducts his business as an operator) during the period of the licence within seven days of such change taking place.

Convictions, Cautions, Driving Offences & Charges etc.

- 8.22** The holder of an operator's licence shall notify the Borough Council in writing if he/she is arrested, released on bail, receives any summons, charge, conviction, caution, formal or informal notice, County Court Judgement or fixed penalty notice within 48 hours of receiving such. The written notification should include the following details:
- Offence / alleged offence;
 - Date, place & time of offence/alleged offence;
 - Whether acting as a hackney/private hire;
 - If motoring offence:
 - whether paying passengers carried;
 - speed or alleged speed;
 - speed limit for road;
 - Punishment e.g. amount of fine, number of penalty points issued etc.
 - whether speed awareness course undertaken
- 8.23** Depending on the circumstances or the number of penalty points accrued on their DVLA driver's licence (if held), operators may be referred to a Panel of the Licensing & Appeals Board. In doing so, the Panel must have regard to all convictions, police cautions, charges, driving convictions, complaints of unacceptable conduct/behaviour, breach of licence conditions and other convictions obtained during the course of a Licence.

- 8.24** Operators should be aware that if they fail to comply with condition 8.22 above, it may prevent the Borough Council from renewing their licence under delegated authority.
- 8.25** The Operator shall provide a suitable number of parking spaces for vehicles awaiting allocation for the conveyance of passengers. These parking spaces must be notified to the Licensing Team at the time of any application or at any time there is a change in these arrangements. The Operator shall ensure that no vehicle, being operated by him, shall at any time park in a position where parking restrictions are in place, at that time, any breach of this condition will be contrary to Section 55 (3) of the Act.
- 8.26** Operators must ensure that non-licensed staff, i.e. controllers, cleaners etc. behave in a civilised and appropriate manner when involved in the operation of the business. This includes discussion on social media sites.
- 8.27** Operators must maintain a register of all non-licensed staff that will take bookings or despatch vehicles. The register must include a record that the Operator has had sight of a basic DBS disclosure check for each staff member.
- 8.28** Operators must have a written process in place to assess previous convictions on employing ex-offenders for non-licensed staff.

Use of Passenger Carrying Vehicles (PCV)

- 8.29** The use of a driver who holds a PCV (over 8 passenger seats) licence and the use of a PSV such as a minibus to undertake a private hire vehicle booking is only permitted with the informed consent of the hirer. Where a PCV is required, the operator must inform the booker that the driver of the PCV is subject to different checks to that of a driver of a private hire vehicle.

Public liability insurance

- 8.30** Operators are required to hold Public Liability Insurance with a minimum cover level of £5m.

9.0 Hackney Carriage Byelaws

Byelaws made under Section 68 of the Town Police Clauses Act, 1847 and Section 171 of the Public Health Act, 1875 by the Borough Council of King's Lynn & West Norfolk with respect to Hackney Carriages.

Interpretation

9.1 Throughout these byelaws "the Borough Council" means the Borough Council of King's Lynn & West Norfolk and "the district" means the Borough Council of King's Lynn & West Norfolk.

Provisions regulating the manner in which the number of each hackney carriage, corresponding with the number of its licence, shall be displayed

9.2 The proprietor of a hackney carriage shall cause the number of the licence granted to him in respect of the carriage to be legibly painted or marked on the outside and inside respectively of the carriage, or on plates affixed thereto.

9.3 A proprietor or driver of a hackney carriage shall:-

- not wilfully or negligently cause or suffer any such number to be concealed from public view while the carriage is standing or plying for hire;
- not cause or permit the carriage to stand or ply for hire with any such painting, marking or plate so defaced that any figure or material particular is illegible.

Provisions regulating how hackney carriages are to be furnished or provided

9.4 The proprietor of a hackney carriage shall:-

- provide sufficient means by which any person in the carriage may communicate with the driver;
- cause the roof or covering to be kept watertight;
- provide any necessary windows and a means of opening and closing not less than one window on each side;
- cause the seats to be properly cushioned or covered;
- cause the floor to be provided with a proper carpet, mat, or other suitable covering;
- cause the fittings and furniture generally to be kept in a clean condition, well maintained and in every way fit for public service;
- provide means for securing luggage if the carriage is so constructed as to carry luggage;
- provide at least two doors for the use of persons conveyed in such carriage and a separate means of ingress and egress for the driver.
- cause the exterior of the carriage to be maintained in a clean condition.

- 9.5** The proprietor of a hackney carriage, except in the case of London Style taxis, shall cause the same to be provided with a sign safely affixed on the roof of the said hackney carriage and so constructed, attached and maintained as to comply with the following requirements, that is to say:
- the said sign shall clearly display to the front of the hackney carriage the word 'TAXI' and shall be kept illuminated during the hours of darkness; these being the hours between half-an-hour after sunset and half-an-hour before sunrise.
- 9.6** The proprietor of a hackney carriage shall cause the same to be provided with a taximeter so constructed, attached, and maintained as to comply with the following requirements, that is to say:
- the taximeter shall be fitted with a key, flag or other device the turning of which will bring the machinery of the taximeter into action and cause the word "HIRED" to appear on the face of the taximeter;
 - such key, flag, or other device shall be capable of being locked in such a position that the machinery of the taximeter is not in action and that no fare is recorded on the face of the taximeter;
 - when the machinery of the taximeter is in action there shall be recorded on the face of the taximeter in clearly legible figures a fare not exceeding the rate or fare which the proprietor or driver is entitled to demand and take for the hire of the carriage by distance in pursuance of the byelaw in that behalf;
 - the word "FARE" shall be printed on the face of the taximeter in plain letters so as clearly to apply to the fare recorded thereon;
 - the taximeter shall be so placed that all letters and figures on the face thereof are at all times plainly visible to any person being conveyed in the carriage, and for that purpose the letters and figures shall be capable of being suitably illuminated during any period of hiring;
 - the taximeter and all the fittings thereof shall be so affixed to the carriage with seals or other appliances that it shall not be practicable for any person to tamper with them except by breaking damaging or permanently displaying the seals or other appliances.

Provisions regulating the conduct of the proprietors and drivers of hackney carriages plying within the district in their several employments, and determining whether such drivers shall wear any and what badges

- 9.7** The driver of a hackney carriage provided with a taximeter shall:-
- when standing or plying for hire, keep the key, flag or other device fitted in pursuance of the byelaw in that behalf locked in the position in which no fare is recorded on the face of the taximeter;
 - before beginning a journey for which a fare is charged for distance and time bring the machinery of the taximeter into action by moving the said key, flag or other device so that the word "HIRED" is legible on the face of the taximeter and keep the machinery of the taximeter in action until the termination of the hiring;
 - cause the dial of the taximeter to be kept properly illuminated throughout any part of a hiring which is during the hours of darkness as defined for the purposes of the Road Traffic Act, 1972 and also at any other time at the request of the hirer.
- 9.8** A proprietor or driver of a hackney carriage shall not tamper with or permit any person to tamper with any taximeter with which the carriage is provided, with the fittings thereof, or with the seals affixed thereto.

- 9.9** Every proprietor or driver of a hackney carriage shall, at all times, when standing, plying, or driving for hire, conduct himself in an orderly manner, and with civility and propriety towards every person seeking to hire, or hiring, or being conveyed in such a carriage shall comply with every reasonable requirement of any person hiring or being conveyed in such carriage.
- 9.10** The driver of a hackney carriage shall, when plying for hire in any street and not actually hired:
- proceed with reasonable speed to one of the stands fixed by the byelaw in that behalf;
 - if a stand, at the time of his arrival, is occupied by the full number of carriages authorised to occupy it, proceed to another stand;
 - on arriving at a stand not already occupied by the full number of carriages authorised to occupy it, station the carriage immediately behind the carriage or carriages on the stand and so as to face in the same direction;
 - from time to time when any other carriage immediately in front is driven off or moved forward cause his carriage to be moved forward so as to fill the place previously occupied by the carriage driven off or moved forward.
- 9.11** A proprietor or driver of a hackney carriage, when standing or plying for hire shall not, by calling out or otherwise, importune any person to hire such carriage and shall not make use of the services of any other person for the purpose.
- 9.12** The driver of a hackney carriage shall take all reasonable precautions to ensure the safety of persons conveyed in or entering or alighting from the vehicle.
- 9.13** The proprietor or driver of a hackney carriage who has agreed or has been hired to be in attendance with the carriage at an appointed time and place shall, unless delayed or prevented by some sufficient cause, punctually attend with such carriage at such appointed time and place.
- 9.14** The driver of a hackney carriage when hired to drive to any particular destination shall, subject to any directions given by the hirer, proceed to that destination by the shortest available route.
- 9.15** A proprietor or driver of a hackney carriage shall not convey or permit to be conveyed in such carriage, any greater number of persons than the number of persons specified on the licence for such carriage issued by the Borough Council.
- 9.16** If a badge has been provided by the Borough Council and delivered to the driver of a hackney carriage, he shall when standing, plying or driving for hire wear that badge in such position and manner as to be plainly and distinctly visible.
- 9.17** The driver of a hackney carriage so constructed as to carry luggage shall, when requested by any person hiring or seeking to hire the carriage:
- convey a reasonable quantity of luggage;
 - afford reasonable assistance in loading and unloading;
 - afford reasonable assistance in removing it to or from the entrance of any house, station or place at which he may take up or set down such person.

- 9.18** Every proprietor or driver of a hackney carriage, who shall knowingly convey in the carriage the dead body of any person shall, immediately notify the fact to the Assistant Director, Legal Services and Licensing.

Provisions fixing the rate of fare to be paid for hackney carriages within the district and securing the due publication of fares

- 9.19** The proprietor or driver of a hackney carriage shall be entitled to demand and take for the hire of the carriage the rate or fare prescribed by the Borough Council, the rate or fare being calculated by distance unless the hirer expresses at the commencement of the hiring his desire to engage by time.
- 9.20** Provided always that where a hackney carriage shall be hired by distance the proprietor or driver thereof shall not be entitled to demand and take a fare greater than that recorded on the face of the taximeter, save for any extra charges authorized by the Borough Council which it may not be possible to record on the face of the taximeter.
- 9.21** the proprietor of a hackney carriage shall cause a statement of the fares fixed by the Borough Council resolution in that behalf to be exhibited inside the carriage, in clearly distinguishable letters and figures.
- 9.22** The proprietor or driver of a hackney carriage bearing a statement of fares in accordance with this byelaw shall not wilfully or negligently cause or suffer the letters or figures in the statement to be concealed or rendered illegible at any time while the carriage is plying or being used for hire.

Provisions securing the safe custody and re-delivery of any property accidentally left in hackney carriages and fixing the charges to be made in respect thereof

- 9.23** The proprietor or driver of a hackney carriage shall immediately after the termination of any hiring or as soon as practicable thereafter carefully search the carriage for any property which may have been accidentally left therein.
- 9.24** The proprietor or driver of a hackney carriage shall, if any property accidentally left therein by any person who may have been conveyed in the carriage be found by or handed to him:
- carry it as soon as possible and in any event within 48 hours, if not sooner claimed by or on behalf of its owner, to the office of the Borough Council and leave it in the custody of the officer in charge of the office on his giving a receipt for it.
 - be entitled to receive from any person to whom the property shall be re-delivered an amount equal to five pence in the pound for its estimated value (or the fare for the distance from the place of finding to the office of the Borough Council whichever be the greater) but not more than five pounds.

Penalties

- 9.25** Every person who shall offend against any of these byelaws shall be liable on summary conviction to a fine not exceeding one hundred pounds and in the case of a continuing offence to a further fine not exceeding five pounds for each day during which the offence continues after conviction.

Repeal of Byelaws

9.26 The byelaws relating to hackney carriages which were made by the Borough Council of King's Lynn & West Norfolk on the 7th day of March 1983 and confirmed by the Secretary of State on the 16th day of September 1983, are hereby repealed. Given under the common seal of the King's Lynn and West Norfolk Borough Council Mayor (T.C.R Legge) & on Borough Secretary (J.H Carr) the 21st day of May 1985. The foregoing byelaw was confirmed by the Secretary of State and came into force on the 1st day of September 1985, signed by P.E Pickering, an assistant secretary in the department of transport on behalf of the secretary of state for transport, 12th August 1985.

10.0 Penalty Points System

10.1 Authorised Officers of the Borough Council can impose penalty points on drivers of private hire vehicles and hackney carriages, proprietors of vehicles and operators of private hire vehicles as shown below. This system is designed for the interest of the public as an aid to ensure continued public safety and to give the individual concerned a chance to rectify any relatively minor breaches of licence conditions without the need to resort to suspension, revocation or prosecution.

10.2 Council penalty points will remain current for the following periods:

- 12 months for a vehicle proprietor licence
- 3 years for a Combined Driver's Licence
- 5 years for a Private Hire Operator's Licence

10.3 If an individual concerned accrues a total of 12 current penalty points then he/she will automatically be referred to a Panel of the Licensing & Appeals Board with a request that the Panel review the individual's continued suitability to hold a licence.

10.4 The following list, whilst not exhaustive, details the circumstances in which a licence holder will be directly referred to a Panel of the Licensing & Appeals Board:

- Providing false or misleading information on licence application form, or failing to provide relevant information including any convictions imposed;
- Authorised officer refused access to operator/driver records;
- Carrying excess passengers;
- Abusive or obstructive behaviour (verbal or physical) to authorised officers of the Borough Council or Police Officers;
- Using a vehicle for which the licence has been suspended or revoked;
- Carrying an offensive weapon in the vehicle;
- Driver not holding a current DVLA licence;
- Nine or more penalty points on a DVLA driving licence;
- Convictions including motoring convictions for:
 - Drinking/drugs and driving;
 - Causing death by careless driving;
 - Reckless/dangerous driving;
 - Offences resulting in disqualification;
 - Disqualified from holding a licence until driving test passed.

10.5 The following list, whilst not exhaustive, details the number of penalty points that will be awarded for the infringements shown:

BC Code	Infringement	Penalty Points
PP1	Failing to notify the Licensing team, in writing of charges, summons, penalty points etc	4
PP2	Displaying any feature on a private hire vehicle which would suggest it is a taxi	4
PP3	Failure to attend the Council Offices when directed by an authorised officer.	6
PP4	Failure to carry an assistance dog without requisite exemption	6
PP5	Failure to notify the Licensing Office of any change in medical fitness to drive.	4
PP6	Failure to notify transfer of vehicle within prescribed time limit	4
PP7	Failure to produce a valid insurance certificate/cover note within 7 days of request.	6
PP8	Failure to produce the 6 monthly MOT/Compliance check	4
PP9	Failure to report to the authority the transfer of a private hire vehicle licence or a hackney carriage proprietor's licence within 14 days of transfer.	4
PP10	Failure to return vehicle licence plate within 7 days after due notice following expiry, revocation or suspension of such licence	4
PP11	Leaving a vehicle unattended on the rank.	4
PP12	Licensed vehicle not carrying a spare wheel, space saver or tyre weld that is capable of being used.	4
PP13	Private hire drivers touting	6
PP14	Private Hire Operator failing to maintain their records in the correct format.	6
PP15	Failing to notify Licensing Team of a change in private hire operator.	4
PP16	Wheelchair accessible hackney carriage not suitably equipped to carry a disabled person in wheelchair	6
PP17	Conviction for minor traffic offences e.g. obstruction, waiting in a restricted street, speeding etc.	3
PP18	Driver smoking, or permitting smoking, in the vehicle	3
PP19	Failing to deal with lost property in the correct manner.	3
PP20	Failing to display fare card (hackney carriage)	3
PP21	Failing to wear a combined driver's licence badge whilst working as a licensed driver.	3
PP22	Failing to notify the Licensing Office in writing, of being involved in an accident or damage being caused by or to a licensed vehicle within 72 hours of the accident occurring.	3
PP23	Failing to notify the Licensing team, in writing, of a change of address within 7 days.	3

PP24	Failure to display any plates, signs or notices required by the Borough Council	3
PP25	Failure to display official 'no smoking' sign in vehicle	3
PP26	Licensed vehicle displaying unauthorised markings (inside or out)	3
PP27	Not having an appropriate fire extinguisher and/or first aid kit in the vehicle.	3
PP28	Parking/stopping contrary to authorised road markings	3
PP29	Parking/stopping with one or more wheels on the pavement	3
PP30	Sounding the vehicle horn to announce arrival or tout for business	3
PP31	Unreasonable prolongation of journeys or any misconduct regarding the charging of fares	3
PP32	Using a mobile phone, radio hand set, eating or drinking whilst the vehicle is in motion	3
PP33	Failure to conform with the Road Traffic Act	3
PP34	Defective vehicle, i.e. bald tyre, headlight not working	4
PP35	Failure to comply with legislation pertaining to hackney carriage and private hire licensing.	3-6

11.0 Summary of Offences

Town Police Clauses Act 1847

<u>Section</u>	<u>Offence</u>
40	Giving false information on application for hackney carriage proprietor's licence
44	Failure to notify change of address of hackney carriage proprietor
45	Plying for hire without a hackney carriage proprietor's licence
47	Hackney driver acting without licence, or proprietors employing unlicensed drivers
52	Failure to display hackney carriage plate
53	Refusal to take a fare
54	Charging more than the agreed fare
55	Obtaining more than the legal fare
56	Travelling less than the lawful distance for an agreed fare
57	Failing to wait after a deposit to wait has been paid
58	Charging more than the legal fare
59	Carrying other person than the hirer without consent
60	Driving a hackney carriage without proprietor's consent
60	Person allowing another to drive a hackney carriage without proprietor's consent
61	Penalty for drunkenness, furious driving, etc. of hackney carriage.
62	Driver leaving hackney carriage unattended
64	Hackney carriage driver obstructing other hackney carriages

Local Government (Miscellaneous Provisions) Act 1976

Hackney Carriage Provisions

49	Failure to notify transfer of hackney carriage proprietor's licence
50(1)	Failure to present hackney carriage for inspection as required
50(2)	Failure to inform Local Authority where hackney carriage is stored if requested
50(3)	Failure to report an accident to Local Authority
50(4)	Failure to produce hackney carriage proprietor's licence and insurance certificate
53(3)	Failure to produce hackney carriage driver's licence
57	Making false statement or withholding information to obtain hackney carriage driver's licence
58(2)	Failure to return plate after notice given after expiry, revocation or suspension of hackney carriage proprietor's licence
61(2)	Failure to surrender driver's licence after suspension, revocation or refusal to renew
64	Permitting any vehicle other than hackney carriage to wait on a hackney carriage stand
66	Charging more than the meter fare for a journey ending outside the district, without prior agreement

67		Charging more than the meter fare when hackney carriage used as private hire vehicle
69		Unnecessarily prolonging a journey
71		Interfering with a taximeter
73(1)(a)		Obstruction of authorised officer or constable
73(1)(b)		Failure to comply with requirement of authorised officer or constable
73(1)(c)		Failure to give information or assistance to authorised officer or constable

Local Government (Miscellaneous Provisions) Act 1976
Private Hire Provisions

46(1)(b)		Driving a private hire vehicle without a private hire driver's licence
46(1)(c)		Proprietor of a private hire vehicle using an unlicensed driver
46(1)(d)		Operating a Private Hire vehicle without a private hire operator's licence
46(1)(e)		Operating a vehicle as a private hire vehicle when the vehicle is not licensed as a private hire vehicle
46(1)(e)		Operating a private hire vehicle when the driver is not licensed as a private hire driver
48(6)		Failure to display private hire vehicle plate
49		Failure to notify transfer of private hire vehicle licence
50(1)		Failure to present private hire vehicle for inspection as required
50(2)		Failure to inform local authority where private hire vehicle is stored if requested
50(3)		Failure to report an accident to local authority
50(4)		Failure to produce a private Hire vehicle licence and insurance certificate
53(3)		Failure to produce a private hire driver's licence
54(2)		Failure to wear a private hire driver's badge
56(2)		Failure by a private hire operator to keep records of bookings
56(3)		Failure by a private hire operator to keep records of private hire vehicles operated by him
56(4)		Failure to produce a private hire operator's licence on request
57		Making false statement or withholding information to obtain a private hire driver's or operator's licence
58(2)		Failure to return a plate after notice given after expiry, revocation or suspension of private hire vehicle licence
61(2)		Failure to surrender a driver's licence after suspension, revocation or refusal to renew
67		Charging more than the meter fare when hackney carriage used as private hire vehicle
69		Unnecessarily prolonging a journey
71		Interfering with a taximeter
73(1)(a)		Obstruction of authorised officer or constable
73(1)(b)		Failure to comply with requirement of authorised officer or constable
73(1)(c)		Failure to give information or assistance to authorised officer or constable

<p>Legal Services & Licensing – Licensing King's Court, Chapel Street, King's Lynn, Norfolk, PE30 1EX Tel: (01553) 616200</p>	<p>Borough Council of King's Lynn & West Norfolk</p>	
<p>Accident & Vehicle Damage Notification Form Local Government (Miscellaneous Provisions) Act 1976 Section 50 (3) Notification</p>		

Note: This notification must be made by the vehicle licence holder/proprietor.

1. PERSON DRIVING THE VEHICLE

Forename/s:		Surname:	
Address:			
(inc postcode)			
Telephone No:	Home:	Mobile:	
Date of Birth:		Sex (M/F):	

2. THE VEHICLE

Hackney Carriage or Private Hire?	
Licence Plate Number:	
Registration Number:	
Operator (if Private Hire):	

3. THE ACCIDENT / INCIDENT CAUSING DAMAGE TO VEHICLE

What was the location of the accident?	
What date did the accident take place?	
At what time?	
Who or what was the accident caused by?	
Is the vehicle considered unroadworthy and not being driven at this present time?	
<p>*Please provide a description of how the accident happened:</p> <p>.....</p> <p>.....</p> <p>.....</p> <p>.....</p> <p>.....</p>	

*You will be asked to draw a diagram of the accident on the next page.

4. SCENE OF THE ACCIDENT / INCIDENT

Please draw a diagram of the scene of the accident. Indicate where your vehicle was, where the other vehicle or object was. Show traffic lights or other road signs and any other vehicles or objects that you remember.

5. VEHICLE DAMAGE / HUMAN INJURY / DAMAGE TO PROPERTY

Please give a full description of the damage to the vehicle and any injury incurred to the driver or other person/s:

.....

.....

.....

.....

6. WHO HAVE YOU INFORMED?

The Police?		If so, give reference number	
Insurance Company?		If so, give claim number	
Operator?		If so, who did you inform?	

In making this notification I confirm the information given is true to the best of my knowledge and I understand it is a criminal offence to provide false information. I also provide consent for an authorised officer of the Borough Council to contact any third party, including my insurance company regarding this accident

Signed by vehicle licence holder:..... Date.....

Legal Services & Licensing– Licensing
King's Court, Chapel Street, King's Lynn,
Norfolk, PE30 1EX
Tel: (01553) 616200

Borough Council of
**King's Lynn &
West Norfolk**



Guidelines Relating to the Relevance of Convictions Hackney Carriage & Private Hire Licensing

1.0 Introduction

1.1 The purpose of these guidelines is to provide guidance on the criteria taken into account by the Council when determining whether or not an applicant or an existing licence holder is a fit and proper person to hold a hackney carriage and/or private hire driver, vehicle or operator licence. The test when considering whether an applicant/licence holder is 'fit and proper' is to pose oneself the following question, 'Without any prejudice, and based on the information before you, would you allow a person for whom you care, regardless of their condition, to travel alone in a vehicle driven by this person at any time of the day or night?'

1.2 The overriding aim of the licensing authority is to protect the safety of the public. The licensing authority is concerned to ensure:

- That a person is a fit and proper and safe and suitable person;
- That the person does not pose a threat to the public;
- That the public are safeguarded from dishonest persons;
- The safeguarding of children, vulnerable adults and young persons.

1.3 This document provides guidance to any person with an interest in hackney carriage and private hire licensing. In particular, but not exclusively:

- Applicants for Drivers' licences;
- Existing Licensed Drivers whose licences are being reviewed;
- Applicants for Private Hire Operator licenses;
- Applicants for Vehicle Licences;
- Existing vehicle licence holders whose licences are being reviewed;
- Licensing Officers;
- Members of the Licensing Panel;
- Magistrates hearing appeals against Local Authority decisions.

1.4 Where Licensing Officers have delegated powers to grant licences, they will utilise these guidelines when making a decision to grant a licence. In all other cases applications for licences will be referred to the Licensing Panel. Whilst Officers and the Panel will have regard to the guidelines contained in the policy, **each case will be considered on its individual merits and, where the circumstances demand, the Panel/Officer may depart from the guidelines.**

2.0 General guidelines

- 2.1** There may be occasions where it is appropriate to depart from the guidelines, for example where the offence is a one-off occasion or there are mitigating circumstances or alternatively where there are many or continuous offences which may show a pattern of offending and unfitness. This authority will consider each case on its own merits and applicants/licence holders are entitled to fair and impartial consideration.
- 2.2** A person with a conviction for a serious offence need not be automatically barred from obtaining a licence, but would normally be expected to:
- 2.2.1 Remain free of conviction for an appropriate period; and
 - 2.2.2 Show adequate evidence that they are a fit and proper person to hold a licence (the onus is on the applicant to produce such evidence). Simply remaining free of conviction may not generally be regarded as adequate evidence that a person is a fit and proper person to hold a licence.
- 2.3** Where an applicant has been convicted of a criminal offence, the licensing authority cannot review the merits of the conviction [Nottingham City Council v. Mohammed Farooq (1998)].
- 3.0 Appeals**
- 3.1** Any applicant refused a driver's licence on the grounds that the licensing authority is not satisfied he/she is a fit and proper person to hold such a licence has a right to appeal to the Magistrates' Court within 21 days of receipt of the notice of refusal [Local Government Miscellaneous Provisions Act 1976, s 77 (1)].
- 4.0 Powers**
- 4.1** Sections 61 and 62 of the Local Government Miscellaneous Provisions Act 1976 allow the licensing authority to suspend, revoke or refuse to renew a licence if the applicant/licence holder has been convicted of an offence involving dishonesty, indecency, violence; failure to comply with the provisions of the Town Police Clauses Act 1847; failure to comply with the provisions of Part II of the Local Government (Miscellaneous Provisions) Act 1976; or any other reasonable cause.
- 4.2** The Rehabilitation of Offenders Act 1974 (Exceptions)(Amendment) Order 2002, allows the licensing authority to take into account all convictions recorded against an applicant or the holder of a private hire vehicle or hackney carriage driver's licence, whether spent or not. Therefore the licensing authority will have regard to all relevant convictions, particularly where there is a long history of offending or a recent pattern of repeat offending.
- 4.3** In this policy the term "disqualification" refers to the period served. In order to take account of the fact that a court may reduce the period of disqualification from driving, an applicant must provide evidence in advance to prove that the court agreed a reduction in the period of disqualification.
- 4.4** It should be noted that "any reasonable cause" includes conduct falling short of a criminal conviction(s).

5.0 Consideration of Disclosed Criminal History

5.1 Under the provisions of Sections 51, 55, and 59, Local Government (Miscellaneous Provisions) Act 1976, the licensing authority is required to ensure that an applicant for the grant or renewal of a hackney carriage and/or a private hire vehicle drivers' licence and/or private hire vehicle operator's licence is a 'fit and proper' person to hold such a licence. However, if an applicant has any convictions, warnings, cautions or charges awaiting trial, the licensing authority will look into:

- How relevant the offence(s) are to the licence being applied for;
- How serious the offence(s) were;
- When the offence(s) were committed;
- The date of conviction;
- Circumstances of the individual concerned;
- Sentence imposed by the court;
- The applicant's age at the time of conviction;
- Whether they form part of a pattern of offending;
- Any other character check considered reasonable (e.g. personal references);
- Any other factors that might be relevant.

5.2 Existing holders of driver licences are required to notify the licensing authority in writing within 48 hours of receiving a driving licence endorsement, fixed penalty notice or criminal conviction (including cautions).

5.3 Applicants can discuss further what effect a caution/conviction may have on any application by contacting the Licensing Team in confidence for advice.

5.4 The licensing authority is also entitled to use other records and information that may be available to it in determining applications or an entitlement to continue holding a licence. This may include information held by the licensing authority or other licensing authorities, and information disclosed by the police or other agencies.

5.5 It is an offence for any person knowingly or recklessly to make a false declaration or to omit any material particular in giving information required by the application for a licence. Where an applicant has made a false statement or a false declaration on their application for the grant or renewal of a licence, the licence will normally be refused.

5.6 It should be noted that the determination of whether an applicant is "fit and proper" or safe and suitable includes consideration of conduct falling short of a criminal conviction.

6.0 Offences involving Loss of Life, Violence, Disorder and Damage to Property

6.1 Licensed drivers have close regular contact with the public. A firm line is to be taken with those who have convictions for offences involving violence, disorder or criminal damage. An application will normally be refused if the applicant has a conviction for an offence that involved the loss of life.

6.2 Anyone with a conviction for an offence involving violence, disorder or damage to property will normally be expected to remain free of such convictions for a period

of at least 5-10 years. However, given the range of the offences, consideration must be given to the nature of the conviction. A licence will not normally be granted if an applicant has more than one conviction in the last 10 years for an offence involving violence or disorder.

- 6.3** In the most serious cases, an application will be refused unless there are exceptional circumstances. A licence will not normally be granted where the applicant has a conviction for an offence such as:
- Murder;
 - Manslaughter;
 - Manslaughter or culpable homicide while driving;
 - Terrorism offences;
 - Or any similar offences (including attempted or conspiracy to commit) or any offences which replace the above.
- 6.4** An application will normally be refused if the applicant has a conviction for an offence or similar offence(s) which replace the offences below and the conviction is less than 10 years prior to the date on which the application is determined by the authority:
- Arson;
 - Malicious wounding or grievous bodily harm;
 - Actual bodily harm;
 - Grievous bodily harm with intent;
 - Robbery;
 - Possession of firearm;
 - Riot;
 - Violent disorder;
 - Any similar offences (including attempted or conspiracy to commit) or any offences which replace the above.
- 6.5** An application will normally be refused if the applicant has a conviction for an offence or similar offence(s) which replace the offences below and the conviction is less than 10 years prior to the date on which the application is determined by the authority:
- Common assault;
 - Assault occasioning actual bodily harm;
 - Affray;
 - Aggravated criminal damage;
 - Any racially aggravated offence;
 - Resisting arrest;
 - Assault police;
 - Or any similar offences (including attempted or conspiracy to commit) or any offences which replace the above.
- 6.6** An application will normally be refused if an applicant has a conviction for an offence or similar offences(s) which replace the offences below and the conviction is less than 3 years prior to the date on which the application is determined by the authority:
- S.5 Public Order Act 1986 offence (harassment, alarm or distress);

- S.4 Public Order Act 1986 offence (fear of provocation of violence);
- S.4A Public Order Act 1986 offence (intentional harassment, alarm or distress);
- Obstruction;
- Criminal damage;
- Or any similar offences (including attempted or conspiracy to commit) or any offences which replace the above.

6.7 A person bound over to keep the peace or be of good behaviour will not normally be granted a licence within the period of the recognisance e.g. where a person is bound over for 6 months, they will not normally be licensed within that 6 month period.

6.8 In the event of a licence being granted, a strict warning both verbally and in writing should be administered.

7.0 Possession of a Weapon & Discrimination

7.1 A conviction for possession of a weapon or any other weapon related offence will raise serious concerns as to the fitness of the applicant to carry the public. Depending on the circumstances of the offence, an applicant should be free of conviction for 7 years (or at least 7 years must have passed since the completion of the sentence, whichever is longer), before a licence is granted.

7.2 Where an applicant has a conviction involving or connected with discrimination in any form, a licence will normally be refused unless a period of 7 years has elapsed since the completion of any sentence imposed.

8.0 Sex, Indecency Offences & Exploitation

8.1 As licensed drivers often carry unaccompanied and vulnerable passengers, applicants with convictions for sexual offences must be closely scrutinised. Those with convictions sexual offences will normally be refused.

8.2 Unless there are exceptional circumstances, an application will normally be refused where the applicant has a conviction for an offence such as:

- Rape;
- Assault by penetration;
- Offences involving children or vulnerable adults;
- Sexual assault;
- Indecent assault;
- Slavery;
- Exploitation;
- Grooming;
- Psychological, emotional or financial abuse;
- Possession of indecent photographs, child pornography etc;
- Exploitation of prostitution;
- Trafficking for sexual exploitation;
- Indecent exposure;
- Soliciting (kerb crawling);
- Or any similar offences (including attempted or conspiracy to commit) offences which replace the above.

8.3 In addition to the above the licensing authority will not normally grant a licence to any applicant who is currently on the Sex Offenders Register or on any barred list.

9.0 Dishonesty

9.1 A licensed private hire vehicle or hackney carriage driver is expected to be a trustworthy person. They deal with cash transactions and valuable property may be left in their vehicles. The widespread practice of delivering unaccompanied property is indicative of the trust that business people place in licensed drivers. Moreover, it is comparatively easy for a dishonest driver to defraud the public by demanding more than the legal or agreed fare, etc. Overseas visitors can be confused by our currency and may be vulnerable to an unscrupulous driver. For all these reasons, a serious view is taken of any conviction involving dishonesty.

9.2 In general, a minimum period of 7 years free of conviction Offences involving dishonesty include:

- Theft;
- Burglary;
- Fraud;
- Benefit fraud;
- Handling or receiving stolen goods;
- Forgery;
- Conspiracy to defraud;
- Obtaining money or property by deception;
- Other deception;
- Taking a vehicle without consent;
- Or any similar offences (including attempted or conspiracy to commit) or any offences which replace the above.

10.0 Drugs

10.1 A serious view is taken of any drug related offence. The nature and quantity of the drugs, whether for personal use or supply are issues that should be considered.

10.2 An application will normally be refused where the applicant has a conviction for an offence related to the **supply of drugs or possession with the intent to supply drugs** and has not been free of such conviction for 10 years.

10.3 An application will normally be refused where the applicant has more than one conviction for offences related to the **possession of drugs** and has not been free of conviction for 5 years.

10.4 An application from an applicant who has an isolated conviction for an offence related to the possession of drugs (with no intent to supply) within the last 5 years will not normally be granted a licence. Consideration should be given to the nature and quantity of the drugs.

10.5 If there is evidence of persistent drugs use, misuse or dependency, a specialist medical examination (in accordance with DVLA Group 2 medical standards) may be required before the licence is granted. If the applicant was an addict then they would normally be required to show evidence of 5 years free from drug taking after detoxification treatment. In addition, any applicant with a conviction for possession of drugs may also have to undergo drugs testing for a period, at their expense to demonstrate that they are not using controlled drugs.

11.0 Minor and Major Traffic Offences

Minor

11.1 Convictions for minor traffic offences e.g. obstruction, waiting in a restricted street, speeding etc. may prevent a person from being granted a hackney carriage or private hire drivers licence if they have received more than 2 motoring convictions within the last 2 years. Where there is a conviction for the offence of driving without due consideration or reasonable care, the matter may be referred to Member's of the Licensing & Appeals Panel to consider the suitability of the person to hold a combined driver's licence.

11.2 The accumulation of 9 or more penalty points will cast grave doubts on the suitability of the applicant and could lead to the refusal of the application.

Major

11.3 A serious view will be taken of any conviction for a major traffic offence, this includes:

- Causing death by dangerous driving;
- Dangerous driving;
- Causing death by careless driving whilst under the influence of drink or drugs;
- Causing death by careless or inconsiderate driving;
- Careless and inconsiderate driving;
- Driving under the influence of drink or drugs etc;
- Driving whilst disqualified;
- Using a vehicle without insurance;
- Offences contrary to the taxi licensing legislation;
- Or any similar offences (including attempted or conspiracy to commit) or an offence that replaces the above.

11.4 These guidelines make specific provision for certain types of major traffic offences to reflect the seriousness of those convictions. In the case of major traffic offences where no such specific provision is made and paragraph 14 (Disqualification) does not apply, an application will normally be refused unless a period of at least 3 years free from conviction of such offences has elapsed.

12.0 Driving Offences involving the Loss of Life

12.1 A very serious view is to be taken of any applicant who has been convicted of a driving offence that resulted in the loss of life. A licence will not normally be granted if they have a conviction for:

- Causing death by dangerous driving;
- Causing death by careless driving whilst under the influence of drink or drugs;

- Or any similar offences (including attempted or conspiracy to commit) or any offences which replace the above.

13.0 Drink Driving/Driving under the Influence of Drugs

- 13.1** As licensees are professional vocational drivers, a serious view is taken of convictions for driving, or being in charge of a vehicle while under the influence of drink or drugs.
- 13.2** An isolated incident would not necessarily debar an applicant from proceeding on the restoration of his DVLA driving licence but he should be warned as to the significant risk to his licence status in the event of re-offending and he must comply with the rehabilitation period below.
- 13.3** More than one conviction for these offences raises significant doubts as to the applicant's fitness to drive the public.
- 13.4** At least 7 years free of conviction, after the restoration of the driving licence following a drink drive conviction should elapse before an application will be considered. If there is any suggestion that the applicant is alcohol or drug dependent, a satisfactory special medical report must be provided (at their own expense) before the application can be allowed to proceed.

14.0 Disqualification

- 14.1** Where an applicant has been disqualified from driving following a conviction for a major traffic offence and no specific provision is made above regarding the appropriate rehabilitation period, the application will generally be refused unless a period of between 3 and 5 years free from conviction has elapsed from the restoration of the DVLA licence.
- 14.2** Where convictions for a number of minor traffic offences have resulted in the applicant being disqualified from driving for a period of time this will normally be taken as reflecting seriously on the applicant's driving standard. Generally, a period of 12 months free from conviction must have elapsed from the restoration of the DVLA licence.
- 14.3** In "totting-up" cases where disqualification is considered by the court, even if the court does not disqualify (e.g. because of exceptional circumstances) a driver, the Council is likely to refuse a hackney carriage or private hire driver's licence because different criteria apply and an applicant will normally be expected to show a period of 12 months free from conviction from the date the court made its finding of exceptional circumstances justifying the non-disqualification.
- 14.4** Any period of disqualification will lead to the suspension/ revocation of a licence.

15.0 Insurance Offences

- 15.1** A serious view will be taken of convictions of driving or being in charge of a vehicle without insurance. An isolated incident in the past will not necessarily prevent a licence being granted provided he/she has been free of such conviction for 3 years; however a strict warning should be given as to future behaviour. More than

one conviction for these offences would normally prevent a licence being granted or renewed.

- 15.2** An operator found guilty of aiding and abetting the driving of passengers for hire and reward whilst without insurance will have his operators' licence revoked immediately and prevented from holding a licence for 3 years.

16.0 Using a hand-held device whilst driving

- 16.1** Where an applicant has a conviction for using a hand-held mobile telephone or hand-held device whilst driving, a licence will not be granted until at least 5 years have elapsed since the conviction or completion of any sentence imposed or driving ban imposed, whichever is the later.

17.0 Cautions

- 17.1** Admission of guilt is required before a caution can be issued. Every case will be considered on its own merits including the details and nature of the offence.
- 17.2** If an applicant has received a caution for a traffic offence, given the nature of the offence and the profession of a taxi driver, the applicant may be given a warning as to his/her future conduct.
- 17.3** Cautions for more serious offences could lead to refusal of an application or the suspension or revocation of a licence.

18.0 Outstanding Charges or Summonses

- 18.1** If the individual is the subject of an outstanding charge or summons their application can continue to be processed, but the application will need to be reviewed at the conclusion of proceedings.
- 18.2** If the outstanding charge or summons involves a serious offence, then in the interests of public safety the application may be put on hold until proceedings are concluded or the licence may be refused.
- 18.3** A suspension or revocation of the licence of a driver takes effect at the end of the period of 21 days beginning with the day on which notice is given to the driver. If it appears that the interests of public safety require the suspension or revocation of the licence to have immediate effect, and the notice given to the driver includes a statement that is so and an explanation why, the suspension or revocation takes effect when the notice is given to the driver. [Road Safety Act 2006, s 52, 2A&2B]

19.0 Licensing Offences

- 19.1** Convictions for offences contrary to taxi legislation such as plying for hire, overcharging and refusing to carry disabled persons would normally prevent a licence being granted or renewed unless the applicant has been free of such convictions for a period of at least 3 years.

20.0 Licences issued by other Licensing Authorities

20.1 Applicants who hold a licence with one licensing authority should not automatically assume that their application will be granted by another. Each case will always be decided on its own merits.

21.0 Summary

21.1 To summarise, a motoring/criminal history in itself may not automatically result in refusal and a current conviction for a serious crime need not bar an applicant permanently from becoming licensed. As the preceding paragraphs indicate, in most cases, an applicant would be expected to remain free from conviction for 3 to 15 years, according to circumstances, before an application can be considered. However, there may be occasions when an application can be allowed before 3 years free from conviction have elapsed.

21.2 Any person who has committed an offence and has to wait before an application is positively considered is more likely to value their licence and act accordingly.

21.3 While it is possible that an applicant may have a number of convictions that, individually, meet the above guidelines, the overall offending history must be considered when assessing an applicant's suitability to be licensed. A series of offences over a period of time is more likely to give cause for concern than an isolated minor conviction. Obviously some discretion can be afforded if an offence disclosed is isolated and there are mitigating circumstances, but the overriding consideration is the protection of the public.

Immediate revocation and suspension of Hackney Carriage and Private Hire Drivers licenses

1. The Borough Council has adopted a procedure to suspend or revoke a driver's licence with immediate effect where the interests of public safety require such course of action. The power under Section 52 of The Road Safety Act 2006 has been delegated to the Assistant Director of Legal Services and Licensing and the Chief Executive of the Borough Council. The below flowchart sets out the procedure adopted:
2. Delegation to; Any Executive Director (ED) or Assistant Director (AED) or Chief Executive (CE) in relation to S52 of the Road Safety Act 2006

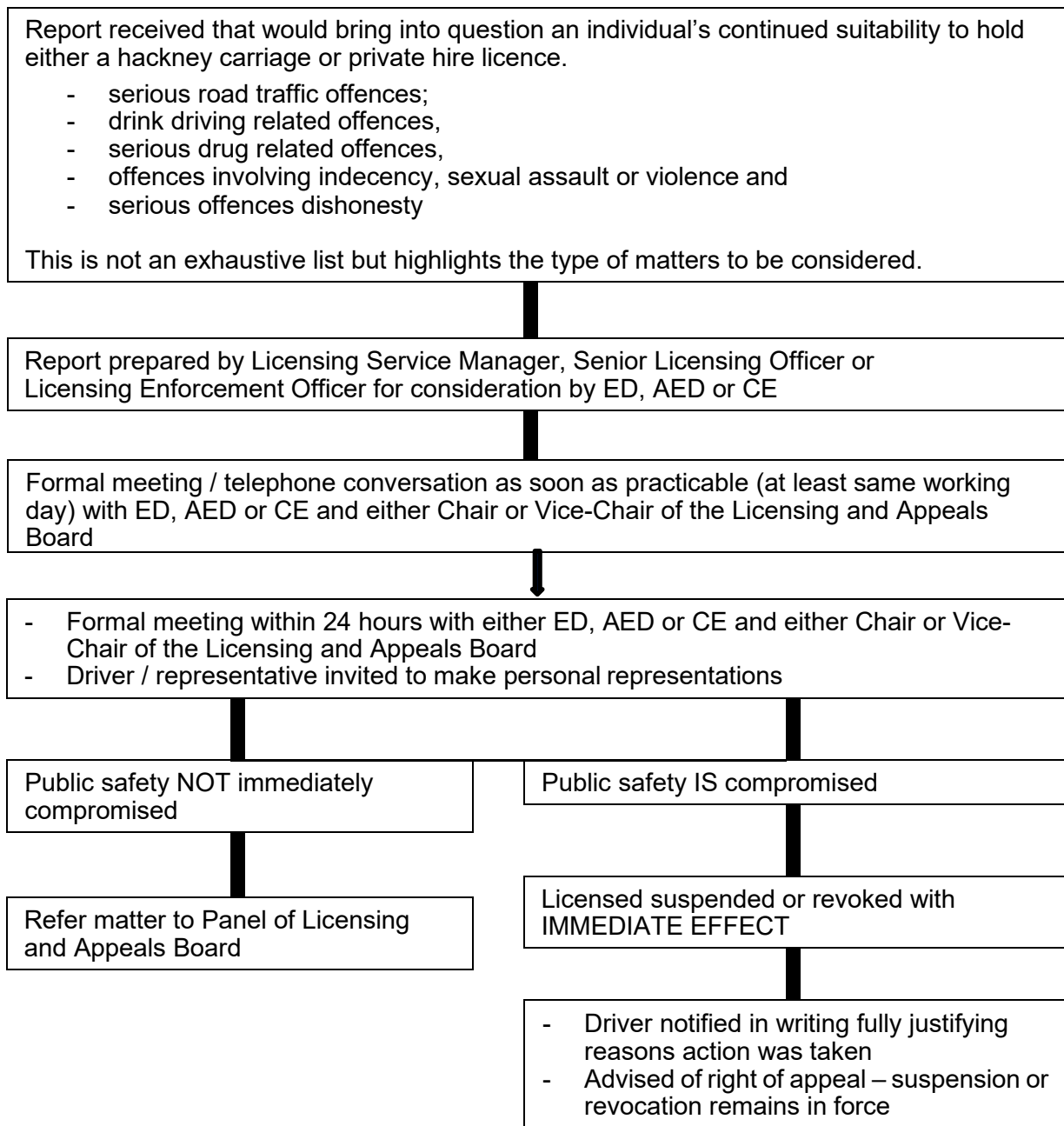

Borough Council of
**King's Lynn &
West Norfolk**



Hackney Carriage & Private Hire Vehicle

Compliance Testing Standards

Code of Practice

**Standards of vehicle test to be applied in addition to
the statutory requirements of the MOT testing**

Introduction

1. This document is intended to provide practical guidance to vehicle testers charged with assessing vehicles being issued with a certificate of compliance. It will also give a general insight into the type of examination the vehicle will be subjected to before it can be issued with a certificate of compliance.
2. It is the responsibility of owners, operators and drivers to ensure that their vehicles comply with the current rules and regulations of the appropriate Road Traffic Act and current Construction and Use Regulations at all times.
3. Where a vehicle is found not to conform to the requirements of the MOT test and/or compliance test standards, that vehicle may have its licence suspended until the Borough Councils authorised officers are satisfied that the vehicle is fit to be licensed.

Guidance

4. No adaptations, alterations, modifications, additional equipment, optional extras with the exception of tow bars fitted to a professional standard, are to be fitted to the vehicles without the prior approval of the Borough Council. Any owner wishing to alter or modify the vehicle, including the fitting of extras or alternative parts to those supplied by the manufacturer must seek prior permission from the Borough Council. Certain modifications may require special inspection by the Borough Council's authorised officer or his nominee before approval is given. (A fee may be applicable)
5. When a vehicle presented for compliance test fails on more than twelve items, that vehicle will have to be re-submitted for a full compliance test and a re-test fee will be charged. The vehicle proprietor will be issued with a failure sheet from the testing station, and the testing station will supply a copy of the failure sheet to The Licensing Team at the Borough Council.
6. Both MOT and compliance tests must be completed by the same examiner at the same test station at the same time of day (obviously MOT testing is completed without avoidable distraction etc so compliance testing may be carried out before or after the MOT inspection). Compliance failure items must be resolved with the same garage at a later date.
7. The Borough Council recognises the need for approved MOT vehicle station examiners to test drive Hackney Carriage and Private Hire vehicles as part of the compliance inspection process.
8. All vehicles (hackney carriages and private hire) require a compliance test before first licence, however they do not require a standard DVSA MOT test unless they are over 1 year from the date of first registration or have a valid DVSA MOT certificate issued within 14 days of the initial new vehicle licence application.
9. Failure of the DVSA MOT test will automatically result in failure of the Borough Council Compliance test.

Contents

- 1. Exterior of the Vehicle**
- 2. Boot**
- 3. Engine Compartment**
- 4. Tyres & Spare Wheels**
- 5. Interior of Vehicle**
- 6. Fire Extinguishers & First Aid**
- 7. Vehicle Signage**
- 8. Underside of Vehicle**
- 9. Wheelchair Facilities**

1.0 EXTERIOR OF THE VEHICLE		
Method of Inspection		Principal Reason for Failure
1.1	The exterior of the bodywork, the underside of vehicle is to be in a clean condition so as to facilitate full inspection of these areas.	Contamination preventing full or proper inspection.
1.2	Check operation of all external locks and catches, ensuring all doors can be securely closed locked and easily opened.	Defective external door catches or locks which prevent a door opening or closing properly.
1.3	Check all doors to ensure that they are aligned properly will open and close easily, and all gaps around doors are reasonably equal. Ensure boot lid opens/closes, and locks correctly and that all hinges and opening mechanisms adequately support the lid when it is in the open position	Poorly fitting doors to the vehicle. Worn locks, hinges or defective boot opening device.
1.4	Check to ensure all door hinges are in good condition, allowing free movement of door.	Door hinges defective
1.5	Check all wind check positions to ensure that doors are held in place when opened.	Wind checks fail to hold doors in place when opened
1.6	Examine the external body panels and structures for any evidence of corrosion, damage, or unsatisfactory repairs.	Corrosion or damage to the vehicle body or structure that adversely affects the appearance and/or safety of the vehicle. Replacement panels fitted that alter the effect of impact zones. Gaps reasonably unequal around panels.
1.7	Examine the external body and paintwork for damage, which adversely affects the appearance of the vehicle.	Generally poor or damaged body or paintwork, dull, not in uniform in colour, and appearance, repairs visible, paint work of poor standard, overspray to any other part of the vehicle.
1.8	Check nearside and offside door/wing mirrors are fitted in a secure manner and that they function correctly. Ensure aerial is securely fixed.	Missing or defective exterior mirrors. Aerial not securely fixed.
1.9	Ensure front and rear bumpers are in good order (without any damage) and are securely fixed to the vehicle.	Damaged or inadequately secured front or rear bumpers, angled dents and end caps.
1.10	Ensure number plates are in good condition and are free of damage, and legible. White reflective at front and yellow reflective at rear.	Damage to front or rear number plates.

	Method of Inspection	Principal Reason for Failure
1.11	Examine rubber seals to doors and windows for damage, looseness or absence affecting performance of seals.	Damage or missing, or loose door seals which may cause draught, rainwater ingress unreasonable road noise or trip hazard.
1.12	Vehicles must be fitted with a key locking fuel cap or an internal means of lock or release.	Vehicle not having a method of securing fuel cap.
1.13	Reversing lights must be operable when fitted.	Reverse lights not operable.
1.14	All windows to be free of cracks and excessive marking.	Cracks in windscreen or rear window. Cracks in side windows or excessive marking on any window.
1.15	Tinted windows must comply with the Road Vehicles (Construction & Use) Regulations that specify the minimum levels of light that must pass through the windscreen and front side windows. The limits are: <ul style="list-style-type: none"> • The light transmitted through the windscreen must be at least 75%; and • The front side windows must allow at least 70% of light to be transmitted through them. 	Windscreen and/or front side window do not meet legal requirements.

2.0 BOOT		
Method of Inspection		Principal Reason for Failure
2.1	Examine the boot interior for evidence of damage, corrosion or water penetration.	Damage to the floor of the boot, inner wing panels or lid.
2.2	Examine the boot floor to ensure that it is in good condition and offers adequate protection to passenger's luggage stored in boot.	Excessive wear, damage or staining to the boot floor.
2.3	Examine interior of boot to ensure it is clean and free of dirt, dust, grease, litter etc.	Accumulation of dirt, grease, dust, litters or rubbish in the boot that could soil or damage luggage stored within. Note: A five litre bottle of engine oil and water will be permitted.
2.4	Check boot for presence of any containers of any flammable or corrosive material (e.g. oil, petrol or diesel).	Containers for the storage of petrol, diesel, or any corrosive material shall not be carried in the vehicle.
2.5	Ensure that boot can be secured by a locking mechanism.	

3.0 ENGINE COMPARTMENT		
Method of Inspection		Principal Reason for Failure
3.1	Carry out visual inspection of engine compartment for signs of fuel, oil or water leaks.	Excessive oil, fuel or water leaks
3.2	Check to ensure that the battery is properly secured in its correct position.	Battery not adequately secured.
3.3	Examine all plastic/rubber or metal hoses for signs of deterioration or damage.	Worn or deteriorated hoses or pipes.
3.4	Check drive belt for correct adjustment and for signs of deterioration or damage.	Incorrectly adjusted or damaged drive belt
3.5	Check security of radiator and check hoses for leaks.	Leaking or insecure radiator.
3.6	Examine engine/transmission mounts for signs of deterioration or wear.	Insecure or deteriorated engine / transmission mountings.
3.7	Check clutch mechanisms for correct operation.	Leakages of fluid or mechanical wear in the clutch mechanisms.
3.8	Check operation of bonnet release/s catches.	Defective bonnet release catch or mechanisms.
3.9	Run engine to normal operational temperature to ensure the engine is not breathing out any excess fumes.	Engine breathing excess fumes.
3.10	Fuel cut off switch to be operable and present where known to be fitted as standard	Switch inoperable or removed.

4.0 TYRES AND SPARE WHEEL		
Method of Inspection		Principal Reason for Failure
4.1	Ensure that spare tyre is of same size and construction as those fitted to the road wheels or manufacturers supplied space saver wheel. Vehicles manufactured without a spare wheel/space saver are allowed a tyre weld.	A spare wheel not provided with the vehicle. A tyre that is of a different size or construction or a non-manufactured supplied space saver wheel. No tyre weld provided
4.2	Examine tyres for signs of damage or excessive uneven wear ensure spare tyre complies with all legal requirements for tyres when fitted to the vehicle.	Damaged, worn, substandard or otherwise illegal tyre.
4.3	Check to ensure all tyres are inflated to correct pressure for the vehicle.	Under inflated tyre.
4.4	Examine the wheel brace and jack provided to ensure they are in good working order.	Failure to provide a suitable jack/wheel brace.
4.5	Check to ensure the spare wheel fixing bracket (or similar device) will hold spare securely in position.	Spare wheel and tools not secured properly.
4.6	Check spare wheel rim for any signs of distortion or damage.	A seriously damaged or distorted rim that impairs the ability to hold the tyre.
4.7	All tyres to have a minimum tread depth of 1.6mm across 75% centre tread width with the remaining 25% to have tread pattern showing, including spare.	Tyres not showing the required tread depth.
4.8	If vehicle fitted with wheel trims as standard for that type of vehicle all must be present and in good repair.	Wheel trims missing, badly scuffed or damaged.
<p>Notes:</p> <ul style="list-style-type: none"> • A mix of steel and cord radials will not be accepted. • Re-cut tyres are not acceptable. • Remould tyres are NOT be acceptable. 		

5.0 INTERIOR OF VEHICLE		
Method of Inspection		Principal Reason for Failure
5.1	Examine all floor and upholstery inside the vehicle for any damage, accumulation of dirt, dust, litter, general debris, cigarette ash, staining, or excessive wear. Examine roof lining for excessive staining and any damage.	A vehicle which is in a dirty condition with accumulations of dust, dirt, litter, debris, damage or staining (including roof lining).
5.2	Remove any mats from floor and examine carpeting for signs of leakage of water into the vehicle.	Evidence of leakage of water into vehicle.
5.3	Examine any mats to ensure they are not worn, damaged or a tripping hazard.	Upholstery including trims and panels which are damaged, excessively worn or holed/torn.
5.4	Sit in each of the seats within the vehicle to ensure that all seat cushions are in good condition and offer proper support.	Seat cushions or back rests which are in poor condition and/or offer poor support.
5.5	The vehicle must have seats with a minimum width of not less than 400mm per person.	Seat width with less than 400mm per person.
5.6	Examine all seats to ensure they are properly secured to the vehicle including fixed seat cushions.	Seats that are not adequately secured to the vehicle.
5.7	Check operation of interior lights, checking both manual and door operated switches. (Note: All doors to have switches fitted if fitted as standard by manufacturer).	Faulty interior light fitting/s or switch/es.
5.8	Examine rear view mirrors to ensure they are securely fixed.	A loose, cracked, damaged or missing rear mirror or one that impairs vision.
5.9	Check operation of the heater and demisters to ensure they work correctly.	Defective heater or demisters.
5.10	Check operation of clutch and also condition of pedal rubbers.	Defective clutch operation, worn or missing pedal rubbers.
5.11	Check operation of rear screen heater to ensure it is functioning correctly.	Defective rear screen heater.
5.12	Check operation of all window winders and door locks ensuring they open and close easily.	Window winders that do not allow windows to be lowered/raised easily. Defective window locks or associated fittings.
5.13	Check the operation of all door release catches including motion door locks to ensure that doors can be opened easily from within the vehicle.	Defective interior door release catches. Defective motion locks, motion locks fitted with override. Warning lamps inoperative, warning labels damaged or defaced.

	Method of Inspection	Principal Reason for Failure
5.14	Ensure childproof locks function correctly where fitted.	Defective childproof locks.
5.15	Check all door handles, and grab rails for condition and security. Ensure childproof protection covers are in place and free of damage and held in place securely.	Door handles, interior trims, mouldings, damaged, worn or not secured properly.
5.16	Check for unpleasant odours within the vehicle.	Unacceptable smells.
5.17	If metal grill is fitted ensure it has no sharp edges or exposed parts that may lead to injury of passengers or driver, ensure grill is firmly secured. (Metal grill must not prevent operation of privacy partition).	Loose or incorrectly fitted grill or exposed parts that may cause injury. Privacy partition obstructed.
5.18	Check that a luggage grill/cover is fitted to estate cars and MPVs.	Luggage grill/cover not fitted.
5.19	Check that intercom systems (where fitted) are capable of being switched off within passenger compartment and that there are signs clearly visible explaining their use and how to switch them off. Check that a light is visible when intercom is on.	Intercom system not clearly marked. No means of passenger isolating system easily. Warning light not working.
5.20	Check condition of all electrical wiring to ensure it's routed correctly and poses no risk or hazard to passengers.	Wiring not routed correctly, insecure, damaged, poses a hazard or risk to passengers.
5.21	CCTV shall be firmly affixed where fitted.	Loose camera or screen fitted
5.22	Ensure gate around lever is present and not split.	Split or missing gaiter can allow debris to fall into gear linkage.
<p><u>Notes:</u></p> <ul style="list-style-type: none"> • 5.1. Vehicles presented in a dirty untidy condition should not be tested. • 5.2. Where interior trims or roof lining have one rip or tear of not more than 75mm a good quality stitched repair is acceptable (patches not allowed). • 5.4. Patching is not acceptable on any interior upholstery • Advice may be given that a roof lining will be required to be renewed at the next test. • 5.17. If a glass partition is fitted this must to British Standards • 5.18. All trims, mouldings, door handles, grab handles to be free of damage. • 5.20 All electrical wiring to be in good order and securely routed. When going through panels the wiring must be protected by rubber grommets. 		

6.0 FIRE EXTINGUISHERS & FIRST AID		
Method of Inspection		Principal Reason for Failure
<u>EXTINGUISHER</u> <u>(IF FITTED)</u>		
6.1	Check to ensure that the fire extinguisher is a 1-litre (3a) rated AFFF (aqueous film foam) type or 1kg dry powder.	Fire extinguisher not of approved type or rating.
6.2	Ensure that seal is in place and has not been tampered with and is intact.	Approved seal is not in place, or is damaged.
6.3	Visibly check extinguisher for signs of damage.	Visible signs of damage that would impair its use.
6.4	Extinguishers to be affixed within the driving compartment or in boot compartment in readily accessible position.	Extinguisher is not mounted securely, not readily accessible, and not mounted in approved position.
<u>FIRST AID</u>		
6.5	<p>A secure and clearly identifiable first aid container must be provided, to contain not less than:</p> <ul style="list-style-type: none"> • 20 Sterile Washproof Plasters • 2 Sterile Dressings • 2 Triangular bandages • 10 Moist Wipes • 2 Sterile Eye wash Pods • 2.5cm Microporous tape • 6 Assorted safety pins • 2 Self Seal waste bags • 1 Pair disposable gloves 	The first aid container is not secure or clearly identifiable. The first aid box does not contain all the items listed opposite.
<p><u>Notes:</u></p> <ul style="list-style-type: none"> • BAFE (British Approvals for Fire Equipment) is the only approved certification and maintenance scheme acceptable to the Authority. • Only persons approved by BAFE may maintain and certify extinguishers fitted to hackney carriage and private hire vehicles. All information concerning the standards for extinguishers is contained within BS EN2. 		

7.0 VEHICLE SIGNAGE		
Method of Inspection		Principal Reason for Failure
<u>HACKNEY CARRIAGE ONLY</u>		
7.1	Roof signs to be white in colour and securely fitted to the vehicle. Minimum Height of 110mm and length of 240mm	Roof sign are not white in colour or securely fitted to vehicle. The roof sign does not comply with specified sizes
7.2	Check that signage is displayed on the roof with the word "TAXI" on the front and lettering is not less than 65mm in height	The specified wording is not displayed on the roof sign or it is below the minimum size.
7.3	Check that the sign shall be capable of being illuminated internally in such a manner that the word "TAXI" is illuminated at all times when the vehicle is plying for hire, but not otherwise.	The roof sign is not capable of being illuminated internally.
<u>PRIVATE HIRE ONLY</u>		
7.5	The private hire vehicle shall not have a roof mounted sign of any kind.	The private hire vehicle has a roof mounted sign.
7.6	The private hire vehicle shall not display any sign, which consists of or includes the word 'Taxi' or 'Cab' whether singular or plural, or 'Hire', or any word of a similar meaning or appearance to any of those words, whether alone or as part of another word. The only exception for use of the word 'Hire' displayed on a private hire vehicle is when the word is used in conjunction with the word 'Private' to form the word 'Private Hire'.	The private hire vehicle has the wording 'taxi' or 'cab' or words of a similar meaning.
7.7	A sign must be displayed on each side of the vehicle that meets the requirements of Conditions 5.5 and 5.6.	There is no signage prominently displayed on each side of the vehicle that meets Conditions 5.5 and 5.6.

8.0 UNDERSIDE OF VEHICLE		
Method of Inspection		Principal Reason for Failure
8.1	Check to ensure the vehicle is free of any leakage of Water, Fuel and Oil.	The vehicle has an excessive fuel, oil or water leakage.
8.2	Check for security/wear in any drive shafts.	Insecure or worn drive shaft components or mounting.
8.3	Check for excess corrosion/damage/ that does not fall within the prescribed area as set out in the MOT tester's manual.	Evidence of excess corrosion/damage to underside of vehicle.
8.4	Check for wear of any engine or transmission mounting that does not fall within the scope of the MOT tester's manual.	Worn or damaged mountings
8.5	Ball joint rubbers to be free of damage.	Missing, torn or damaged mountings.
8.6	Damaged, torn or insecure inner drive shaft gaiters	Release of lubrication from joint.
<p><u>Notes:</u></p> <ul style="list-style-type: none"> When a vehicle fails on fuel, oil, water leaks, on re-test it will be left running for no less than five minutes prior to inspection. 		

9.0 WHEELCHAIR FACILITIES¹		
	Method of Inspection	Principal Reason for Failure
9.1	Check condition of wheelchair restraints and equipment	Wheelchair restraints or equipment worn damaged or missing.
9.2	Check operation of wheelchair restraints.	Wheelchair restraints not functioning correctly.
9.3	Check operation and condition of disabled person's seatbelt.	Seatbelt worn, frayed, damaged or cut.
9.4	Check that appropriate approved ramps are securely installed in the boot of the vehicle.	Ramps not of an approved type, fitting or insecure.
9.5	Examine the ramps for any damage, sharp edges or corners.	Ramps in poor condition or damaged or sharp edges showing.
9.6	Check as applicable the non-slip provision and locating dowel pins are free of any damage.	Non slip provision worn or damaged, locating dowels damaged, worn or missing.
9.7	A wheelchair space shall not be less than: <ul style="list-style-type: none"> • 1200mm measured in the longitudinal plane of the vehicle • 750mm measured in the transverse plane of the vehicle • 1350mm measured vertically from any part of the floor of the wheelchair space. 	Wheelchair space is less than: <ul style="list-style-type: none"> • 1200mm measured in the longitudinal plane of the vehicle • 750mm measured in the transverse plane of the vehicle • 1350mm measured vertically from any part of the floor of the wheelchair space
9.8	A wheelchair space shall allow the carriage of a wheelchair and a wheelchair user facing the front of the vehicle.	Wheelchair space does not allow carriage of wheelchair user facing frontwards.
9.9	Access to the vehicle must be possible from the road or pavement either by a lift or ramp. Any power-operated device must be capable of manual operation in the event of a power failure.	Access to vehicle is not possible from road or pavement by lift or ramp. Lifting device not capable of operating with no power.
9.10	A ramp should be of slip resistance material and at least 750mm in width. The ramp should be capable of being deployed both onto the road and onto a 125mm high kerb. The ramp when deployed should be securely located at the point of entry to the vehicle. For side & rear loading the ramp when deployed to the pavement should not exceed a slope of 1:4.	Ramp not slip resistant material. Width less than 750mm and not capable of being deployed onto 125mm high kerb. Ramp not securely located at entry point of vehicle. Slope exceeds 1:4.
9.11	The lift platform must be not less than 750mm in width and not less than 1200mm in length. The platform should be equipped with a device to prevent the wheelchair rolling off and should operate at a vertical speed of less than 0.15m/s.	Lift platform less than 750mm in width or 1200mm in length. No device to prevent wheelchair rolling off platform.
9.12	A 4 point anchorage system must be fitted, comprising two for attachment at the front of the wheelchair and two at the rear of the wheelchair, in accordance with ISO 10542-2.	No 4 point anchorage system installed in accordance with ISO 10542-2.

¹ Any additional Hackney Carriage Vehicle licenses issued must be wheelchair accessible (i.e. plate 53 onwards).

Legal Services and Licensing – Licensing
King's Court, Chapel Street, King's Lynn, Norfolk, PE30 1EX
Tel: (01553) 616200

Borough Council of
**King's Lynn &
West Norfolk**



Vehicle Checklist.

Engine Compartment

Check all fluids are at the correct level, Brake fluid, coolant, Oil and Power Steering (Where applicable).
Check there are no apparent leaks visible in engine compartment or under the vehicle
Check the Battery is Secure and free from corrosion.

Drivers Seat

Check the Foot Brake works correctly without excessive travel.
Check the Hand Brake / E-Brake work correctly.
Check the Steering does not have excessive play.
Check all Mirrors are fitted and are clean and free from damage, providing good visibility.
Check Dashboard warning lamps work correctly, and no warnings remain once engine is started.
Washers and wipers are working correctly and free from damage. clearing the screen without issue.
Check all controls work correctly as designed including the horn. Note the horn must not be checked between the hours of 23:00 and 07:00 and should be checked in a non-residential area. When not possible to check at initial startup this should be checked at the first suitable opportunity.

Interior General

Check all seats are secure and in good clean condition.
Check all Seatbelts work correctly and are free from damage.
Check all doors and windows open and close correctly and door handles work from both inside and outside the vehicle.
Check all interior fittings are in good condition.
Check interior licence correctly displayed and valid.
Check fare Chart displayed and meter correct and working (Hackney Carriage)

Exterior of vehicle

Check all Lights including indicator side repeaters are working correctly, are clean, correct colour and free from damage.
Check all bodywork including bumpers, is in good condition with no damage and all panels are secure.
Check all wheels and tyres are correct size, free from damage, no missing wheel nuts with no cord visible on any tyre.
Check all Tyres have minimum tread depth of 1.6mm across the centre 75% of tyre width.
Check exhaust is secure and free from leaks.
Check that the Rear Licence plate and both number plates are displayed correctly, are clean and free from damage.
Check the Roof Light is secure and illumination is working correctly (Hackney Carriage).
Check both Door Signs are in good condition, free from damage and not faded (Private Hire)